



Raising gas analysis to new levels

SERIES 4

QUASAR

CHEMILUMINESCENT NOX ANALYSER

OPERATING MANUAL



www.signal-group.com

Signal Group Ltd
Standards House, Doman Road, Camberley, Surrey GU15 3DF
United Kingdom

Tel: +44 (0)1276 682841 Email: sales@signal-group.com



ISO
9001 : 2015
REGISTERED

Cert No. 337032019



DOCUMENT HISTORY

ISSUE	AMENDMENT	DATE
1.01	First Release	February 2020

Table 1 : Document history table

© Signal Group Ltd.

All rights reserved. No part of this manual may be reproduced, stored in a retrieval system or transmitted in any form or by any means - electronic, mechanical, photocopying, recording or otherwise - without the prior written permission of Signal Group Ltd.

While we believe that the information and guidance given in this manual is correct, all parties must rely upon their own skill and judgment when making use of it. Signal Group Ltd. will not assume any liability to anyone for any loss or damage caused by any error or omission in the manual, whether such error or omission is the result of negligence or any other cause. Any and all such liability is disclaimed.

The information contained within this document is subject to change without notice.



Contents

1	What's in the box	5
2	Important safety instructions	7
2.1	Wiring and Installation.....	7
2.2	Handling and Storing Pressurised Gases.....	7
2.3	Operation and Maintenance.....	8
2.4	Competent Personnel	9
3	Quick-start	10
4	Introduction.....	12
5	The Principle of Chemiluminescence	13
5.1	Sample System.....	13
6	Flow Schemes	14
7	Operation.....	15
7.1	Services.....	15
7.2	Start.....	15
7.3	Control.....	18
7.4	Remote Control.....	19
7.5	Connectivity	20
7.6	Shut-down	24
8	Routine Maintenance	25
8.1	Introduction	25
8.2	Sample Filter.....	25
8.3	Other Filters.....	26
8.4	Ozone Trap Cartridge Replacement	28
9	Routine Servicing.....	29
9.1	Schedule.....	29
9.2	Service Manual	29
9.3	Sample Capillary.....	29
9.4	Ozone Capillary	31
9.5	Vacuum Pump	32
10	Specifications	32
10.1	Setup Specification	32
10.1-1	External pipe fittings.....	32
10.1-2	Inlet pressures	32
10.1-3	Ranges	32



10.1-4	Ozone Flow Rate	Error! Bookmark not defined.
10.1-5	Sample Flow Rate	Error! Bookmark not defined.
10.1-6	Temperature Setup	32
10.1-7	Pressure Setup	32
10.2	System Specification.....	33
10.2-1	Detector	33
10.2-2	Carbon Number Correlation	Error! Bookmark not defined.
10.2-3	Catalytic Air Purifier	Error! Bookmark not defined.
10.2-4	Sample System.....	33
10.2-5	Heating	33
10.2-6	Safety	33
10.2-7	Power	33
10.2-8	Environment	33
10.2-1	Zero Air.....	33
10.2-2	Linearity	33
10.2-3	Stability	33
10.2-4	Noise	33
10.2-5	Oxygen Synergism.....	Error! Bookmark not defined.
11	Table of Figures	34
12	Table of Tables.....	34



1 What's in the box

- Signal Series 4 QUASAR analyser
- Signal USB Drive containing:
 - Operating Manual
 - S4i User Guide
 - S4i installation
 - Datasheet
 - Test Reports
- Shipping kit containing – Signal Part No. 3000/380010:
 - 2m Mains lead cable
 - Sample filter key
 - 9/16" Wrench
 - 7/16" Wrench
 - 11/16" Wrench
 - USB drive with related documents
- Analogue output connection cable – Signal Part No. MI/995 (Optional)
- Relay output connection cable – Signal Part No. MI/996 (Optional)
- Pump control cable – Signal Part No.xxxx (Option)
- Ethernet connection cable - Signal Part No.xxxx (Option)
- Power cable



Read This First



Signal Group Ltd designs, manufactures and tests its products to meet many national and international standards. Because these instruments are sophisticated technical products, you **MUST** properly install, use, and maintain them to ensure they continue to operate within their normal specifications. The following instructions **MUST** be adhered to and integrated into your safety program when installing, using and maintaining Signal Group Ltd products. Failure to follow the proper instructions may cause any one of the following situations to occur: Loss of life; personal injury; property damage; damage to this instrument; and warranty invalidation.

- Read all instructions prior to installing, operating, and servicing the product.
- If you do not understand any of the instructions, contact your Signal Group Ltd representative for clarification.
- Follow all warnings, cautions, and instructions marked on and supplied with the product.
- Inform and educate your personnel in the proper installation, operation, and maintenance of the product.
- Install your equipment as specified in the Installation Instructions of the appropriate Instruction Manual and per applicable local and national codes. Connect all products to the proper electrical and pressure sources.
- To ensure proper performance, use qualified personnel to install, operate, update, program, and maintain the product.
- When replacement parts are required, ensure that qualified people use replacement parts specified by Signal Group Ltd. Unauthorised parts and procedures can affect the product's performance, place the safe operation of your process at risk, and **VOID YOUR WARRANTY**. Substitutions may result in fire, electrical hazards, or improper operation.
- Ensure that all equipment doors are closed, and protective covers are in place, except when maintenance is being performed by qualified persons, to prevent electrical shock and personal injury.



2 Important safety instructions

2.1 Wiring and Installation

The following safety instructions apply to all EU member states and should be followed according to Low Voltage Directive. It is recommended that non-EU areas should also comply with these instructions unless superseded by other local or national standards.

- It is essential that suitable grounding connections be made at all connectors provided for this purpose.
- All safety covers and grounding connections must be properly reinstated after maintenance or troubleshooting. The integrity of all earth terminals must always be maintained.
- To ensure safe operation of this equipment, connection to the mains supply should be made through a circuit breaker which will disconnect all circuits carrying conductors in the case of a fault. These circuit breakers should comply with a recognised standard such as IEC947. All wiring must conform to any local or national standards.

2.2 Handling and Storing Pressurised Gases

This instrument requires pressurised gases for use. Some general safety precautions are outlined below; however, it is advisable that operators are properly trained in the handling and storage of pressurised gas containers:

- Never drop cylinders or permit them to strike each other violently.
- Cylinders may be stored in the open, but in such cases should be protected against extremes of weather and, to prevent rusting, from the dampness of the ground. Cylinders should be stored in the shade when located in areas where extreme temperatures are likely.
- The valve protection cap should be left on each cylinder until it has been safely secured against a wall or other solid structure or placed in a dedicated cylinder stand.
- Avoid dragging, rolling or sliding cylinders, even for a short distance – they should be moved using a suitable transportation device (e.g. bottle trolley).
- Never tamper with the safety devices in valves or cylinders.
- Avoid storage of full and empty cylinders together. Serious suck-back can occur when empty cylinders are attached to pressurised systems.
- No part of a cylinder should be exposed to a temperature higher than 52°C (125°F), or a naked flame or incandescent material.
- Do not place cylinders where they could become part of an electric circuit.



2.3 Operation and Maintenance

On leaving the Signal Group Ltd factory, this product confirmed to all applicable safety directives. The operator must take care to follow the instructions given in this manual to preserve this condition.

Before switching on the instrument, ensure that the local supply voltage is within the limits indicated in this manual.

Any interruption of the protective earth connections, whether inside or outside of the unit, or removal or interruption of its ground line connection, may result in reduced instrument performance and exposure to the risk of electrocution. It is therefore strictly forbidden to deliberately disconnect the protective earth.

The removal of covers and panels may expose electrical components. Connectors may also be energised even if no mating connector is present. The unit should therefore be disconnected from all electrical supplies before any kind of maintenance or repair is carried out. Only trained personnel who are aware of the risk are permitted to energise an open unit.

Fuses may only be replaced with identical items. It is forbidden to use repaired fuses or to bypass fuses.

Substances hazardous to health may escape from the unit's gas outlets. It is advisable to exhaust the gas outlets to a safely ventilated area.

The safety of the personnel operating this equipment is paramount. All efforts should be taken to ensure their protection.

Our analysers are checked and tested using state of the art equipment and techniques. Despite this, an element of risk remains to the user when using any gas analyser. Even when operated as intended and observing all applicable safety instructions and standards, some risks remain, including but not limited to the following:

- An accidental interruption of the protective earth line, e.g. In an extension cable, may result in a risk to the user;
- Electrically live components may be exposed if operating the instrument with covers removed;
- The emission of hazardous gases may be possible even if all connections have been made correctly and according to the manufacturers' instructions.

Avoid exposure to the dangers of these residual risks by taking care when installing, operating, maintaining and servicing the analyser.

If unsure about anything in this manual, please contact your local Signal Group Ltd representative for further guidance.



2.4 *Competent Personnel*

Specialist knowledge of this instrumentation is a necessity for working with and on the unit.

Authorised personnel for installing, operating, servicing, and maintaining the analyser are instructed and trained personnel of the operating company, Signal Group Ltd or their local representatives.

- It is the responsibility of the operating company to:
 - Ensure their staff have adequate training.
 - Observe safety regulations.
 - Follow this instruction manual.
- Operators must:
 - Have been properly trained.
 - Have read and understood all relevant sections of the instruction manual before commencing use of the instrument.
 - Know all the applicable safety mechanisms and regulations.

To avoid personal injury and loss of property, do not install, operate, maintain or service this instrument before reading and understanding this manual and receiving appropriate training.

Do not dispose of this instruction manual.



3 Quick-start



Please read all safety instructions before operating the analyser



This section is intended as a quick guide for trained personnel. See the Operation section for detailed instructions.

- Connect your power supply to the mains IEC connector on the rear panel (for standard AC operation);
- Connect both Vacuum and Bypass pumps to their respective inlet ports;
- Connect your gases to the rear panel at the following pressures, using tubing as indicated below:

Gas	Tube	Pressure
Air/O ₂	1/4" PTFE or similar	0.75Bar ±0.25Bar
Zero (N ₂)	1/8" PTFE or similar	0.75Bar ±0.25Bar
Span/Calibration Gas (NO/NH ₃)	1/8" PTFE or similar	0.75Bar ±0.25Bar
Sample	1/4" PTFE or similar	0.5Bar ±0.2Bar

Table 2 : Quick-start setup

- Switch on the power using the switch on the rear panel (AC operation only). At this stage you should see a solid blue LED on the front panel, indicating that the unit is in Sleep mode. An internal fan may also be audible;
- Your instrument is now powered up and ready for general use. The various internal heated components require time to warm up. Depending on your chosen options, this may be as long as 45 minutes. Use your chosen operating interface (front panel display or S4i. See the appropriate user guide for detailed information) to proceed and initiate the warmup procedure;
- The following options will initiate warmup:

Standby – the unit will go to a state ready for measurement. No gas valves will be open.

Zero – the unit will automatically initiate heating, and once up to temperature, will open the zero valve to begin measuring zero gas.

Span – as Zero but for Span.

Sample – as Zero but the unit will begin measuring Sample gas once warmed-up.



- For optimal performance you need to calibrate your instrument. (It is recommended to do this daily) You can calibrate from the following modes:

Zero – calibration in this mode will adjust the zero offset only.

Span – calibration in this mode will adjust the span coefficient only.

Sample – calibration in this mode will adjust the zero offset, followed by the span coefficient.

NOTE – it is advisable to leave your instrument lit for at least an hour before first calibration.

Further details regarding calibration can be found in Section 7.

- Once calibrated and stable, your instrument is ready for accurate measurement. Use the relevant user interface guide for further information regarding instrument features such as analogue outputs and data logging, and how to configure and use them.



4 Introduction

The Signal QUASAR range of gas analysers uses reference-method Chemiluminescence (CLD) technology to determine the total NO_x content of gas samples.

Specifically designed to be versatile and reliable, and function equally well in tough applications, such as Continuous Emissions Monitoring (CEM), engine certification and gas turbine research and development, the QUASAR range has the performance to meet your analysis requirements. Proprietary digital flow and temperature control, together with Signal's world-class Series 4 electronics package, provides superior performance across the board.

- Standard QUASAR analysers allow optional:
- Measurement ranges as low as 1ppm NO equivalent up to as high as 1% NO equivalent;
- Heating (Oven up to 200°C, NO_x Converter up to 440°C);
- Ozone generation;
- Ammonia (NH₃) or NO_x Conversion;
- Fully automated calibration;
- Continuous measurement of Nitric Oxide (NO), Nitrogen Dioxide (NO₂) and NO_x gases;
- 10 user-programmable analogue outputs for monitoring concentrations, ranges, pressures and/or temperatures;
- Up to 35 user-programmable relay outputs for alarm or external valve operation;
- Remote control and data logging over Wi-Fi, Ethernet or RS232;
- On-board data logging;
- 24VDC power supply.

Signal is renowned for its ability to create instruments for special applications, so if the options above do not cover your specific requirements then contact Signal or one of their local representatives to discuss your application further.



5 The Principle of Chemiluminescence

The reaction chambers in this instrument introduce nitric oxide and ozone into an environment under vacuum. When the two molecules react, they produce nitrogen dioxide (NO₂), oxygen and a small amount of light. Contained within the detector component of the analyser is a photomultiplier tube, which multiplies the amount of emitted light and converts it into electrons. Once the low-level photon light has been measured and converted, the dynode within the system acts as an electron multiplier. The amplified electrons add up to output signals in the form of a current which can be translated into a chosen unit of molecular concentration (e.g. ppm, mg/m³ etc.)

Chemiluminescence under vacuum offers higher sensitivity with minimal quenching effects, and a heated reaction chamber facilitates the processing of hot, wet sample gases without condensation.

5.1 Sample System

The compact 3U 19" rack unit includes a 191 °C heated sample handling module which houses the CLD, a sample particulate filter, a sample selection solenoid, sample and ozone capillaries, and connections to the zero and span selection valves.

The sample handling module allows the connection of a heated sample line directly to the rear panel preventing cold spots where sample condensation may occur. It uses the well proven make-up air bypass system to prevent sample condensation problems at the regulator. Make-up air is added to the sample path from the bypass air supply at a point down-stream of the sample extraction point. This creates a constant flow at the sample dump port. The sample is never in contact with the control components.



6 Flow Schemes

Pictured below in Figure 2 is the flow scheme for the DNOx Quasar:

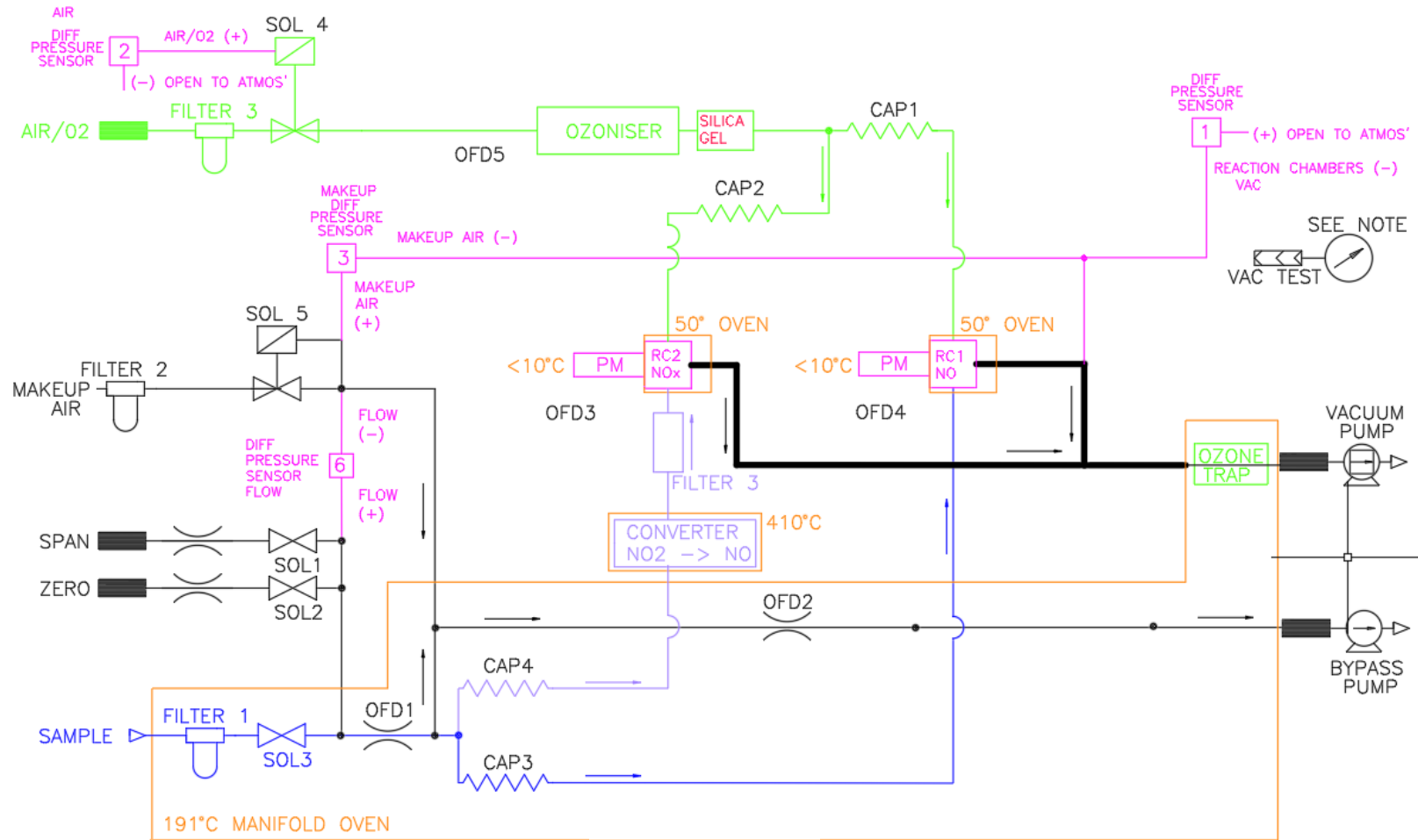

Figure 1 : NOx Quasar Flow Scheme



7 Operation

7.1 Services

Signal Group Ltd assumes that the user has a certain level of understanding of gas analysers. Some aspects of gas analysis can be dangerous without proper training and understanding. Signal and its representatives are able to provide full analyser training on request. Contact your local representative for further information.

To use your QUASAR analyser, you will need the following services:

- **Power:** QUASAR's standard universal power supply allows operation from 220VAC to 240VAC at 50 to 60Hz. 600W maximum.

24DC operation is available on request. Please ask for details.

- **Air:** It is recommended that you have zero-grade compressed air available for supply to the ozoniser via the Air/O₂ port (maximum 6.5L/min at 1bar).
- **Span Gas:** NO/NH₃ in N₂. Signal recommends a gas concentration close to the expected measurement level. For greatest accuracy, the balance gas should contain a similar Nitrogen concentration to the sample gas.
- **Zero Gas:** Zero-grade nitrogen – is used for analyser calibration.
- **Bypass Pump:** Maintains flow within the system.
- **Vacuum Pump:** Sufficiently powerful vacuum pump that can pull down at least a vacuum of 5 mbar below atmosphere.
 - The pumps can be controlled via the Pump Control connection (4 pin connector bottom left of Figure XXX), please contact your Signal-Group representative for advice.

7.2 Start

- Ensure that the analyser is resting on a stable surface or fixed into a rack, or on a wall if the wall-mount option has been chosen.
- Connect the included (or equivalent) power cable to the rear panel IEC power socket, ensuring the supply voltage is within the operational limits of the instrument;

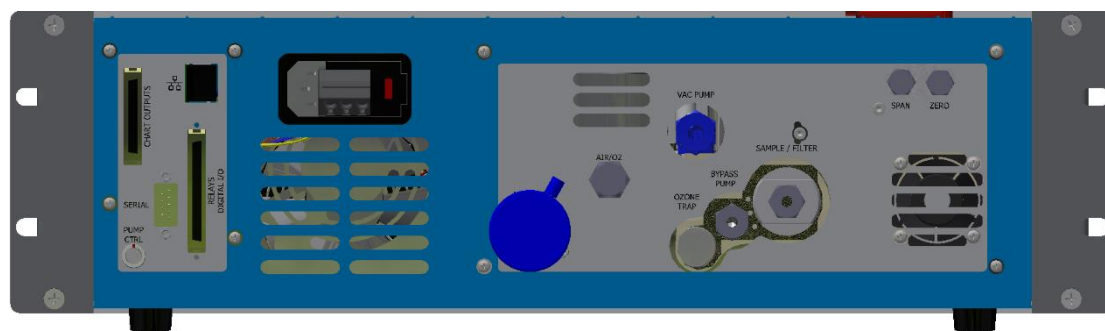
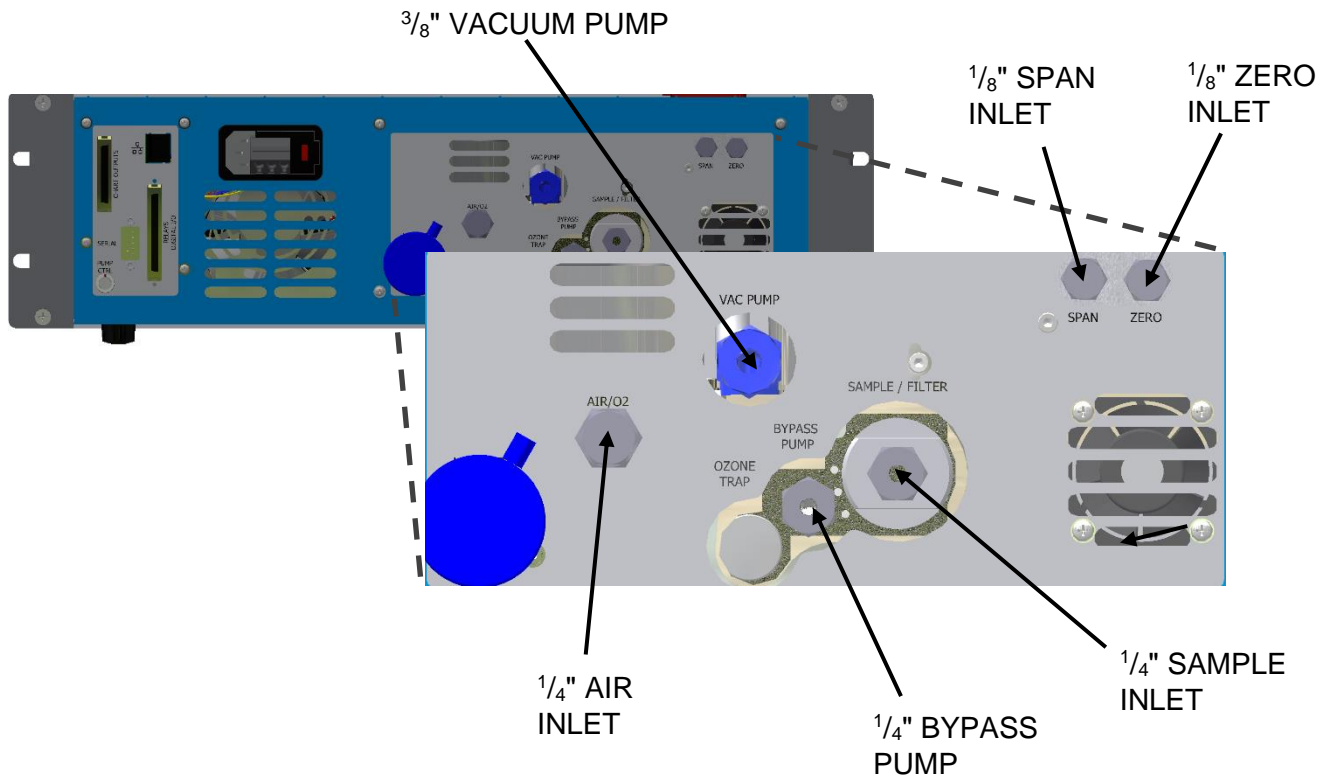

Figure 2 : Quasar rear panel



- Ensure that the correct fuses are in place within the integrated IEC socket on the rear panel.

Figure 3 : Quasar CLD pneumatic connections

- **AIR** : Ensure that the correct air supply is available;
 - A continuous supply of pressurised air is required, at $0.75\pm 0.25\text{bar}$ ($50\pm 25\text{kPa}$, $10\pm 3.6\text{psi}$).
 - Zero-grade air must be provided for accurate readings. If you do not have this in a bottle it is recommended that you use an external air purifier to achieve the best performance from the Ozoniser. Consult your local Signal Group Ltd representative for further advice. Connect your chosen air supply to the AIR/O₂ port on the rear panel.
- **SPAN**
 - Connect your chosen span calibration gas to the $\frac{1}{8}$ " SPAN port on the rear of the analyser (e.g. 1000ppm NO in N₂). Use a regulator to provide the span gas to the analyser at a pressure of $0.75\pm 0.25\text{bar}$. It is recommended that the concentration value of your span gas should be between 40% and 80% of your chosen measurement range.
- **ZERO**
 - Connect your chosen zero calibration gas to the $\frac{1}{8}$ " ZERO port on the rear of the analyser (e.g. Nitrogen). Use a regulator to provide the zero gas to the analyser at a pressure of $0.75\pm 0.25\text{bar}$. Ensure that the regulator and piping are clean and not



contaminated. If they have been used with high concentrations of NO, water vapour, or CO₂, they should be purged with clean air for at least 2 hours.

– **SAMPLE**

- Connect your sample supply to the SAMPLE/FILTER port on the rear panel at 0 to 10 psi. It is recommended that the sample gas temperature be maintained at a level above the dew point of the measurand(s), e.g. 191°C, using a heated sample line obtainable from Signal Group Ltd.

– **PUMPS**

- Connect your Vacuum Pump to the 'VAC PUMP' port on the rear of the panel, ensure the pump can pull down to a vacuum of at least 5 mbar absolute. To test this, place a vacuum gauge on the inlet of the pump and deadhead the inlet to the gauge.
 - Connect your Bypass pump to the 'BYPASS PUMP' port on the rear panel. Dependant on the outlet size of your pump you may need to add a fitting to the bypass port to fit the relevant pipework.
 - It is advised that you connect the outlet of the vacuum pump to a damper to stabilise readings and reduce noise. Similarly, you can connect the outlet of the bypass pump and the damper to an extraction port for noise-reduction.
-
- If desired, attach your chosen output cables (analogue/relays/etc) now. Preassembled cables can be purchased separately from Signal Group Ltd. Contact your local representative for details. Alternatively, see the Output Wiring section of this manual for connection information.
 - When all the fittings and cables are secure, you may apply power to the unit by using the switch on the rear panel (this applies to units powered by mains AC only. 24VDC units should use an external switch capable of carrying up to 25Amps if switching 24VDC, 3.15 Amps (for 230VAC) or 6.5Amps (for 115VAC), if switching the primary side of an AC-DC transformer.
 - The front panel Status LED should now be illuminated solid blue. This indicates that the unit is in Sleep mode.



7.3 Control

Once the analyser is powered on it may be controlled using either the bundled S4i program (See the S4i User Guide for further information), or the optional front panel display.

Password Protection (front panel display only)

- The front panel display is under development. Please contact your Signal-Group representative for the latest user manuals

Zero/Span Calibration

- The procedures for calibration of the zero offset and span coefficient are fully automated.
- First, enter the span gas bottle concentration values as described in your chosen interface guide. Then, simply select Calibrate while the unit is warmed-up and stable to initiate the process. It will then monitor the measurements to determine the point at which they have become stable enough to use as a reference for calibration. Once stability is achieved, the unit will monitor the measurements for a short period before setting the correct values.
 - For best accuracy, allow the instrument to stabilise for at least 1 hour after it is up to temperature before attempting to calibrate.
 - Before attempting any calibration, ensure that the correct gases are connected.
 - Before attempting a Span calibration, ensure that the span gas table is complete with the correct gas values, as described on the gas cylinder certificate. Failure to do this may result in large errors in measurement and/or unexpected readings.
 - Note: As of version 5.6.15 there is a known issue with the S4i span gas table that prevents the NO₂ value from being entered, please contact your Signal-Group representative for advice on how to enter the values. This issue has been resolved in the detachable tablet display.
 - Each measurement range has its own individual zero offset and span coefficient. Select Apply Calib. to All Ranges before any calibration if you wish to use the same offset and coefficient for all ranges.
- You may begin a Calibration from any of the following modes:
 - **ZERO:** only the zero offset is adjusted.
 - **SPAN:** only the span coefficient is adjusted.
 - **SAMPLE:** First the zero-gas path is automatically selected and the zero-offset adjusted, then the adjustment of the span coefficient is performed with the span gas path selected.

Calibration Failure

- The calibration routine automatically waits for a stable reading before applying the results. If a stable reading cannot be found within the built-in time limit, then the calibration will fail, and an alarm will be activated. There are many reasons that a stable reading would not be found. It is advisable to contact your local Signal Service representative for advice if this occurs.

Measurement

- Once the unit is warmed-up and fully calibrated, accurate measurements can be taken.



- Select Sample mode to energise the heated internal sample valve and allow sample gas to flow.
- You may check the calibration at any time by switching to Zero or Span gas paths and monitoring the measurements.

Ranges

- The instrument has a single hardware range (e.g. 1000ppm, 4000ppm / 1%) allowing accurate measurement from zero to full scale of the instrument at all times, regardless of selected user range. However, it is standard practice (and often dictated by regulations) to choose a suitable range for measurement. For this reason, consult your local regulations for further guidance on the use of ranges.
- To enable compliance with various regulations, 5 ranges are provided, together with an auto range facility. Each of these ranges is programmable by the user, apart from the maximum range which is fixed.
- Four of the five ranges are standard 0-n type, with a fixed lower end, but the fifth is m-n, which means that it has a programmable lower end allowing the expansion of the specific range of measurement. For example, if the expected range of measurement is 11 to 18ppm, an instrument range of 5 to 25ppm may be chosen. The main benefit of this facility is that it allows for greater resolution on the analogue outputs.
 - NOTE: Each range uses separate calibration curves and coefficients. Ensure that all the ranges that will be in use are properly calibrated before taking measurements.
 - NOTE: Due to the capability of separate calibrations for each range, it may appear that one range measures differently to another. In this case it is necessary to recalibrate in order to realign the measurements. Always apply the calibration to all ranges to avoid inter-range differences.

Pressures and Temperatures

- The home page of the S4interface shows all of the relevant temperatures and pressures present within the analyser. In order for the analyser to work as intended, all of these values need to be within the specification required. See section 10.1 for the necessary temperature and pressure values.

7.4 Remote Control

Consult the S4i User Guide (available to download at www.signal-group.com) for detailed remote-control operational guidance.



7.5 Connectivity

Relays

- The Analyser can be fitted with up to 35 contact closure output relays which can be configured to operate when in alarm states, or to actuate valves for a particular detector, range and gas path.
- The following output relays are available depending on your selected option:
 - Standard IO – 3 (non-configurable)
 - Extended IO – 23 (20 configurable)
 - Special Extended IO – 35 (32 configurable)
- I/O cables, MI/1020 can be ordered separately to connect to the Relay outputs.

Relay specification

- Load: Resistive load ($\cos\phi = 1$)
 - Rated Load: 0.5 A at 125 VAC; 1 A at 24 VDC
 - Contact Material: Ag (Au alloy)
 - Rated Carry Current: 2 A
 - Max. switching voltage: 125 VAC, 60 VDC
 - Max. switching current: 1 A
 - Max. switching power: 62.5 VA, 30 W
 - Failure rate (reference value): 1 mA at 5 VDC
- P level: $\lambda_{60} = 0.1 \times 10^{-6}/\text{operation}$. This value was measured at a switching frequency of 120 operations/min and the criterion of contact resistance is 100. This value may vary depending on the operating environment. Always double-check relay suitability under actual operating conditions.

**MI/1020**

Relay No/Digital IO	Pin	Colour	Relay No/Digital IO	Pin	Colour
1	1	Brown	18	18	LightGreen
	68	White/Red		51	Pink/Black
2	2	Brown/Green	19	19	LightGreen/Brown
	67	Purple/Green		50	White/Black
3	3	Red	20	20	LightBlue
	66	LightBlue/Gray		49	Gray/Green
4	4	Orange	22	21	Green/White
	65	Pink/Gray		48	Gray/Black
5	5	Orange/Brown	GLB ALB23 (NO)	22	Yellow/Red
	64	Purple/Yellow	GLB ALA23 (Com)	47	Purple/White
6	6	Yellow	GLB ALC23 (NC)	23	Blue/Red
	63	Yellow/Gray	GND Power	46	Purple/Black
7	7	Green	+24V Fused Output	24	LightBlue/Red
	62	Green/Brown	TTL Sleep	45	Blue/Black
8	8	Pink/Green	NC	25	Green/Red
	61	Yellow/White	TTL CAL	44	LightBlue/Yellow
9	9	Blue/Green	GND POWER	26	Green/Orange
	60	Orange/White	GND POWER	43	Pink/Blue
10	10	Green/Yellow	DIO1	27	yellow/Gray
	59	Red/White	DIO9	42	Pink/Red
11	11	Blue	DIO2	28	LightGreen/Green
	58	LightBlue/Green	DIO10	41	Green/Black
12	12	Purple	DIO3	29	Yellow/Brown
	57	Blue/Orange	DIO11	40	Yellow/Black
13	13	Purple/Red	DIO4	30	Brown/Yellow
	56	Yellow/Blue	DIO12	39	Orange/Gray
14	14	Gray	DIO5	31	Brown/Pink
	55	Blue/White	DIO13	38	Orange/Black
15	15	Gray/Red	DIO6	32	LighBlue/Brown
	54	LightBlue/Black	DIO14	37	Red/Black
16	16	White	DIO7	33	Gray/Brown
	53	LightGreen/Gray	DIO15	36	Brown/White
17	17	Pink	DIO8	34	Black
	52	LightGreen/Black	DIO16	35	Brown/Black

Table 3 : Relay wiring table - Colours refer to Signal output cable MI/1020

**MI/996 (Legacy data cable)**

Relay No/Digital IO	Pin	Colour	Relay No/Digital IO	Pin	Colour
1	1	Pink	18	18	Grey
	68	Black		51	Black
2	2	Pink	19	19	Grey
	67	Pink		50	Pink
3	3	Pink	20	20	Grey
	66	Blue		49	Grey
4	4	Pink	22	21	Grey
	65	Green		48	Purple
5	5	Pink	GLB ALB23 (NO)	22	Grey
	64	Yellow	GLB ALA23 (Com)	47	Blue
6	6	Pink	GLB ALC23 (NC)	23	Grey
	63	Orange	GND Power	46	Green
7	7	White	+24V Fused Output	24	Yellow
	62	Red	TTL Sleep	45	Orange
8	8	White	NC	25	Grey
	61	Brown	TTL CAL	44	Red
9	9	White	GND POWER	26	Purple
	60	Black	GND POWER	43	Brown
10	10	White	DIO1	27	Purple
	59	Pink	DIO9	42	Black
11	11	White	DIO2	28	Purple
	58	Purple	DIO10	41	Green
12	12	White	DIO3	29	Purple
	57	Blue	DIO11	40	Green
13	13	White		30	Purple
	56	Green	DIO12	39	Yellow
14	14	White	DIO5	31	Purple
	55	Yellow	DIO13	38	Orange
15	15	White	DIO6	32	Purple
	54	Orange	DIO14	37	Red
16	16	White	DIO7	33	Purple
	53	Red	DIO15	36	Brown
17	17	Grey	DIO8	34	Blue
	52	Brown	DIO16	35	Black

Table 4 : Relay wiring table - Colours refer to Signal output cable MI/996



Analogue Outputs

- Five 0-10Vdc analogue outputs are included as standard. These may be used for chart recordings, to connect to an external datalogger, or to operate external alarms. Ten analogue outputs are available with extended and special extended IO options. Up to ten isolated 4-20mA outputs are also optionally available. (MI/995)
- These outputs are typically configured to provide measurements from each gas detector channel (scaled to the range in use), and to indicate the range in use. For range indication, 1V = range 1 (lowest range), 2V = range 2, etc.
- The outputs may also be configured by users to provide outputs of internally measured temperatures and pressures. This can be useful for fault finding as well as tracking sample flows

MI/995

Ch number	Pin Number	Old Pin Colour	New Pin Colour
1	1	Pink	Brown
	26	Black	White
2	2	Pink	Yellow
	27	Brown	Green
3	3	White	Pink
	28	Black	Grey
4	4	White	Red
	29	Brown	Blue
5	5	White	Violet
	30	Red	Black
6	6	White	Red/Blue
	31	Orange	Grey/Pink
7	7	White	White/Pink
	32	Yellow	Brown/Green
8	8	White	White/Green
	33	Green	Grey/Brown
9	9	White	White/Yellow
	34	Blue	White/Grey
10	10	White	Yellow/Brown
	35	Purple	Pink/Brown

Table 5 : Chart Output Pinout Colour



7.6 Shut-down

- Press the 'STANDBY' button on the S4interface. The analyser will stop measuring and all internal functions not necessary for operation will be turned off. The full shutdown procedure will take several minutes while the sample and ozone lines are being purged.
- The condition STANDBY will be displayed when the shutdown procedure is complete.
- When STANDBY is displayed, turn the pumps off. Wait for two minutes while the vacuum chamber pressure returns to ambient. It is important that the vacuum and bypass pumps are not disconnected until the chamber pressure is at ambient otherwise damage to the internal pressure sensors may occur.
- Switch the analyser into 'SLEEP' mode via the S4i to keep the analyser on but not in a readily-usable state. Alternatively, turn off the analyser completely via the power switch found on the rear panel.
- Close all valves on the zero, span and air supplies. Disconnect all piping and cables. The sample inlet, vacuum outlet and bypass outlet on the analyser WILL BE HOT. Take care to avoid skin contact with the fittings until they cool.
- Heated lines should purge with cool, clean air for thirty minutes to reduce the line temperature. Do not tightly coil the heated line until it is cool (below 60 °C to 70 °C).
- Coiling when hot may cause the PTFE inner tubing to kink causing restricted flow next time it is used. If the line must be coiled before it is cool, use large loops and take particular care to avoid skin contact with the hot line ends.



8 Routine Maintenance

8.1 Introduction

The analyser requires little routine maintenance to keep it in good working order.

If the analyser is used infrequently, check the filter and Zero/Span calibration every time it is used.

If the analyser is used continuously, check the filter and Zero/Span calibration once per week or as experience dictates. The filter may need to be checked at different intervals depending on the particulate content of the sample gas. Zero/span calibration may need to be checked at different intervals depending on the local variations in ambient temperature and/or atmospheric pressure.

8.2 Sample Filter

CAUTION

If the analyser has been switched on, the filter housing may be too hot to touch. The filter replacement tool provides a method for changing hot filter elements.

Dirty Filters may contain corrosive compounds. Use gloves. Obey local safety measures.

Signal recommends and supplies PTFE filters (Part number FILT/023) for use as internal Sample filter in all Solar and Quasar instruments. These PTFE filters may be cleaned and re-used.

Glass fibre filters are not recommended for use in our heated analysers. They can be damaged during installation into the heated manifold and fibres can become detached and block critical sample paths.

Removal/Replacement

Before filter removal, ensure that the Sample gas line has been shut off using an external valve, or that the process has been paused to allow for safe servicing of the analyser.

- Disconnect the sample gas line from the back of the instrument.
- The filter is immediately behind the pipe fitting. The pipe fitting and filter cap are removed as a single item using a special tool. Identify the filter extraction tool (MC/318011), supplied in the accessory kit. Using the filter extraction tool, release the filter cap by rotating $\frac{1}{4}$ turn anti-clockwise.
- Reverse the filter extraction tool and screw it onto the pipe fitting.
- Withdraw the housing, taking care not to touch the hot surfaces.
- The filter element will be found protruding from the cap. It will quickly cool and may be removed by hand. Dirty filters can contain corrosive compounds. Use gloves.



- Lightly soiled filters may be cleaned following the guidelines below. Clean the filter or fit a replacement filter element if heavily soiled.
- Re-assemble the filter cap to the analyser using the reverse procedure and reconnect the sample line.

New filter elements are available from Signal with part number FILT/023.

NOTE: If you did not purchase a spares kit with the analyser, consider purchasing one now. Several kits are available which contain items that you will find useful in your servicing and maintenance schedules.

Cleaning

The preferred cleaning method is to immerse the filter in an ultrasonic bath containing a solution of 1 part 'Ardrox® 6333' to 4 parts water at a temperature of 70°C for a period of 10 minutes or until all surface particles are removed.

Ardrox® is a registered trademark of Chemetall GmbH and is available from them or their distributors. It is an aqueous based liquid concentrate comprising a blend of alkali builders, sequestrants, corrosion inhibitors and biodegradable surfactants.

ARDROX	
Appearance	Pale, yellow liquid
Density	1.07 g/ml at 20°C
Flash Point	Non-flammable
pH	12.3
Storage requirements	Protect from freezing conditions

Table 6 : Ardrex Information

8.3 Other Filters

The following replaceable filters are located inside the instrument and should be changed at routine service intervals, or when contaminated:

- Makeup Inlet Filter: Signal Part Number FILT/025 (see Figure 5 – Located on the rear panel of the analyser on the makeup air intake) – DETAIL A
- Air filter: Signal Part Number FILT/030 (see Figure 5 – Located on top of Ozoniser regulator assembly) – DETAIL B
- Converter filter: Signal Part Number FILT/030 (see Figure 5 – Located on connection between Converter and Reaction Chamber) – DETAIL C

Take care not to damage the plastic filter body when replacing.

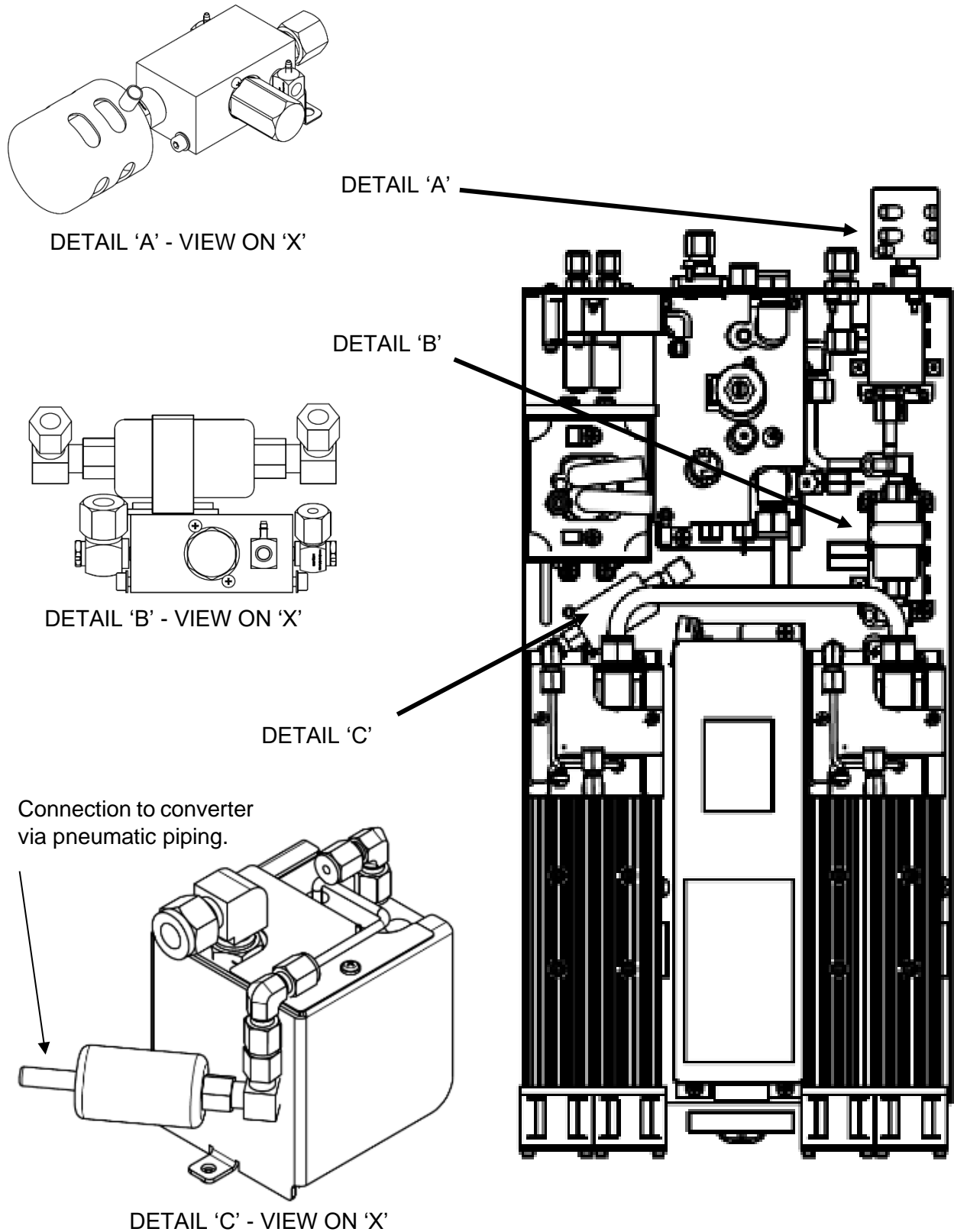

Figure 4 : Quasar Filter Details



8.4 Ozone Trap Cartridge Replacement

Quasars contain a porous catalyst which is susceptible to degradation after prolonged use as well as other external factors like vibration and fatigue. This is contained within a conveniently replaceable cartridge, accessible from the rear panel. The cartridge comprises of various components. To replace the cartridge see instructions below utilising **Error! Reference source not found.** for further clarity;

- Locate the cartridge end cap (Item 4 – MC/371511) and using a 6mm Allen key, unscrew anticlockwise until loose.
- Carefully take out the knit mesh once the cap is removed to expose the ‘closed’ end of the cartridge.
- Withdraw the cartridge by fastening an M2 screw into the threaded hole on the face of the cartridge, **only fasten the M2 screw 2mm deep** as there is a mesh inside the cartridge which can be broken if the m2 bolt is inserted too far. With the bolt in place, use a pair of pliers to pull out the cartridge.
- The old cartridge can either be sent back to Signal for a refurbishment or it can be disposed of (it contains no harmful components so it can be disposed of safely adhering to local requirements).
- Ensure the new cartridge has an appropriate ‘o’ ring (Item 3 – O’RING/167) before reinserting the cutter body, if not slide over the end on the cartridge into the groove.
- Re-insert the cartridge and mesh into the analyser.
- Replace the cartridge end cap to complete the cartridge replacement ensuring the cap is tightly fastened to avoid leaks.

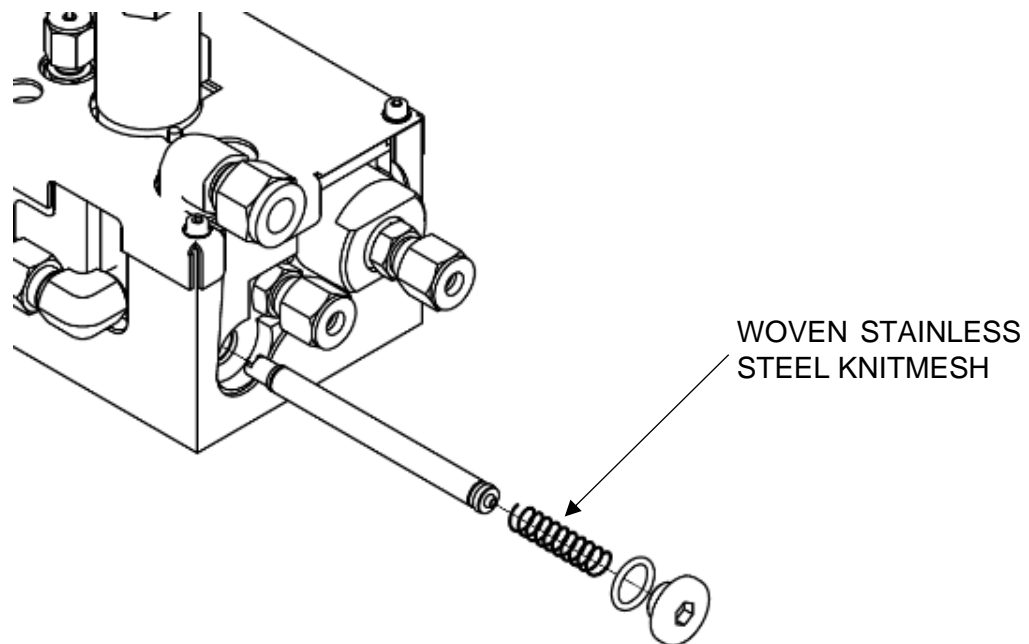

Figure 5 : Ozone Trap Cartridge Details



9 Routine Servicing

9.1 Schedule

The analyser requires regular servicing to maintain its accuracy and operational status.

Servicing should be carried out by a qualified service engineer with electrical and pneumatic experience. If you do not have these in-house skills, contact your local Signal representative who will be pleased to assist you.

Item	Frequency
Replace Sample Capillary	When the calibration procedure repeatedly fails.
Electronic Calibration	After changing the sample capillary or if the analyser continuously fails normal calibration.

Table 7 : Servicing frequency

9.2 Service Manual

Full service manuals are normally only issued to distributors and agents. However, they can be purchased by those who wish to carry out their own servicing. Signal recommend attendance of a complete service training course prior to attempting a service.

Note: All warranty will cease if a customer carries out their own servicing during the warranty period unless special arrangements have been made in writing.

9.3 Sample Capillary

CAUTION

The oven is at 191 °C during operation. Allow at least 2 hours for it to cool before attempting capillary replacement.

If the analyser has been used without a sample filter, or with a sample containing compounds that can condense at temperatures lower than 191 °C and the shutdown procedure is not followed, the sample capillary may become blocked.

Removal/Replacement

- Remove the analyser from any rack or housing and place upside down on a firm, clean bench. It is very important that the work surface and all tools are clean to prevent particulate entering the manifold block or sample capillary.
- Locate the access plate on the base of the analyser. Remove the screws, plate, and insulation to reveal the capillaries.

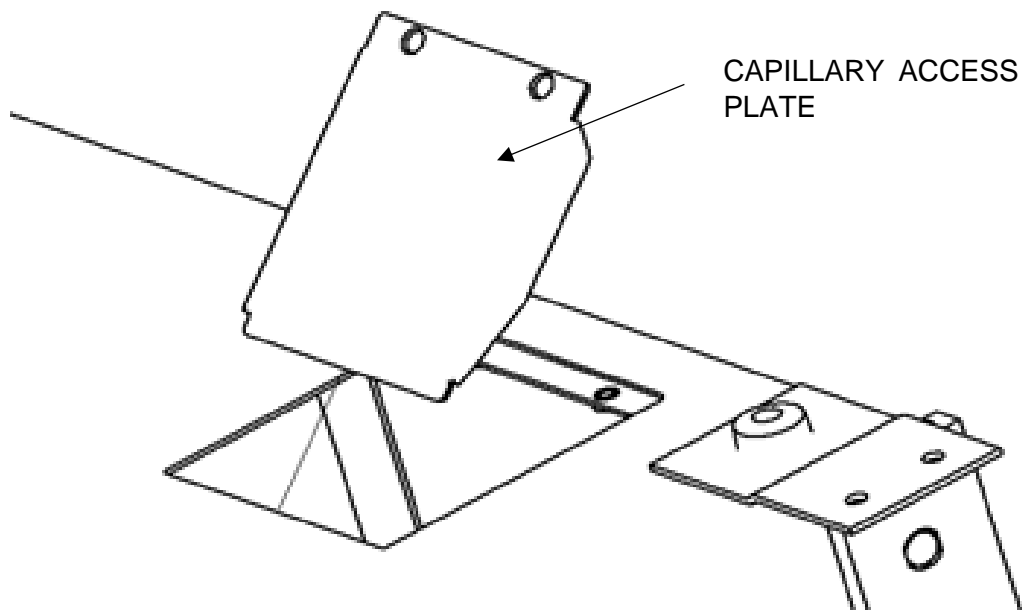

Figure 6 : Capillary access plate

- Using a small brush or vacuum cleaner, remove all particulate from around the capillary
- Disconnect and replace the capillary. The Quasar has 2 sample capillaries, both of which should have a flow rate of 40 ml/min at ambient temperature under a pressure of 5 PSI.

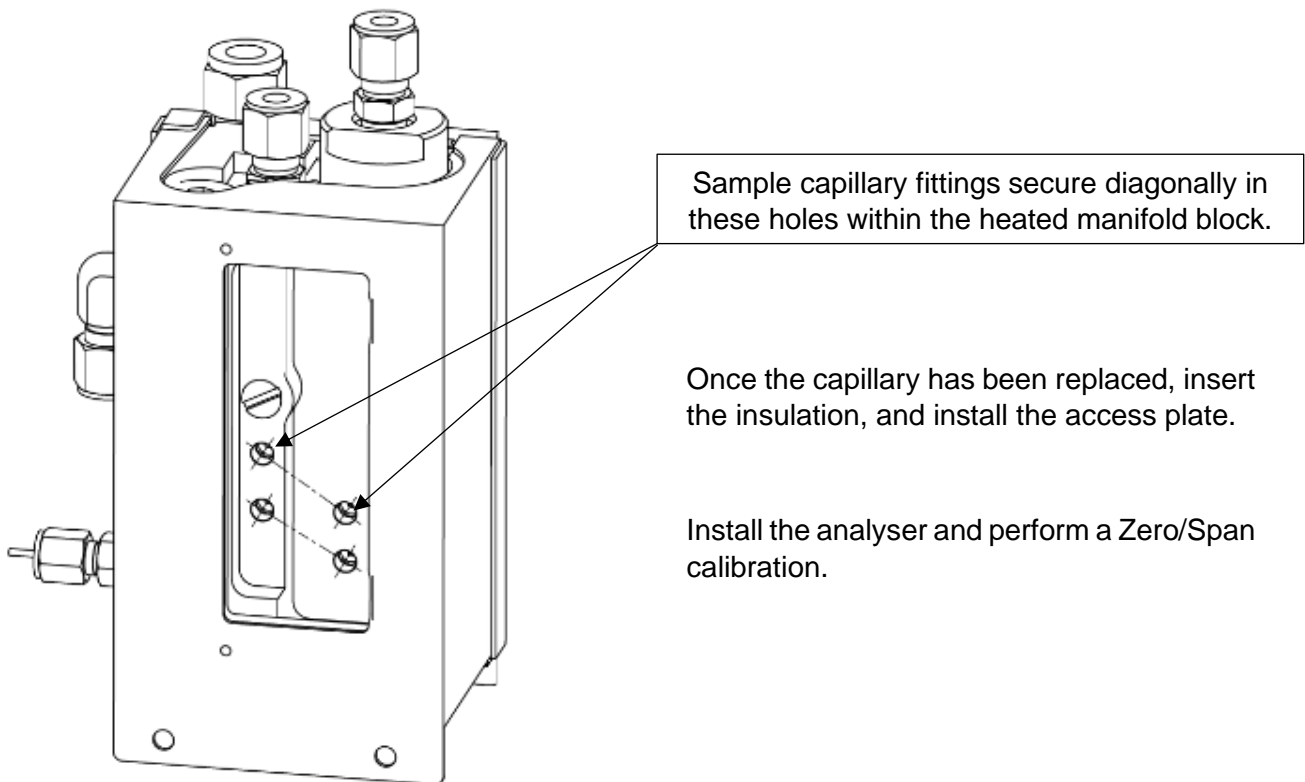

Figure 7 : Quasar capillary locations



9.4 Ozone Capillary

The ozone capillaries are susceptible to blockages within the reaction chamber due to the vacuum within the system. If your NO – NO_x balance is off, this could be attributable to an ozone capillary block.

Removal/Replacement

- Remove the analyser from any rack or housing and place on a firm, clean bench. It is very important that the work surface and all tools are clean to prevent particulate entering the reaction chamber block or ozone capillary.
- Locate the Reaction Chambers at the end of the detectors, remove the screws to the top plate of the component and take out the fibrefrax insulation.
- Disconnect the $\frac{1}{8}$ " pipe from the top of the ozone capillary and undo the M6 ferrule nut that secures the capillary to the reaction chamber. When the nut is loose, ensure that you take it out carefully as there are small $\frac{1}{8}$ " / $\frac{1}{16}$ " ferrules at either end of the capillary.
- Replace the blocked/both capillaries, using the nuts and ferrules from the removed component in the new capillary, if necessary.
- Once fitted, insert the insulation back into the chamber and re-install the top plate to the reaction chamber assembly.

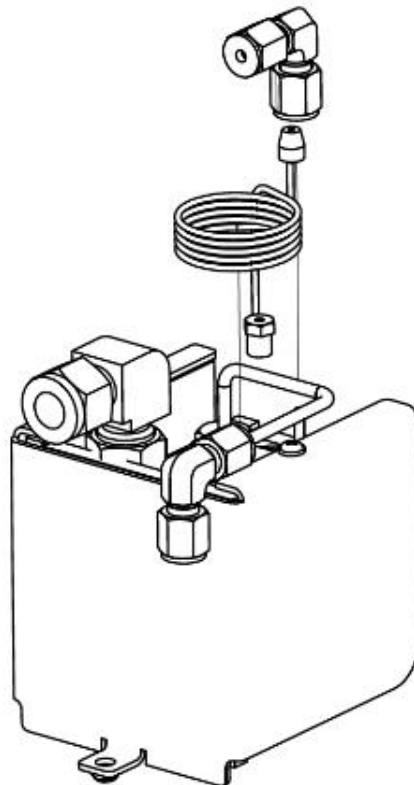

Figure 8 : Ozone Capillary Detail



9.5 Vacuum Pump

Whilst not part of the analyser itself, it is imperative that the vacuum pump used, pulls down to a sufficient level. Vacuum pumps can worsen over time with constant usage, with dry vac pumps being susceptible to diaphragm degradation. Ensure that your pump is regularly serviced and creates a vacuum of at least 5 mbar absolute. A good indicator if your pump is starting to degrade is to monitor the vacuum value on the S4i when in use, if this value falls it could be due to the pump.

10 Specifications

10.1 Setup Specification

10.1-1 External pipe fittings

- Sample inlet, and Air inlet = 1/4" tube fitting
- Span inlet, and Zero inlet = 1/8" tube fitting
- Vacuum Pump and Bypass Pump = 3/8" tube fitting

10.1-2 Inlet pressures

- Air inlet = 0.75Bar \pm 0.25Bar
- Span and Zero inlet = 0.75Bar \pm 0.25Bar
- Sample inlet = 0.4Bar \pm 0.2Bar

10.1-3 Ranges

- 0-1 ppm, 0-10 ppm, 0-100 ppm, 0-1,000 ppm OR
- 0-10 ppm, 0-100 ppm, 0-1,000 ppm, 0-10,000 ppm (1%) OR
- 0-100 ppm, 0-1,000 ppm, 0-10,000 ppm (1%), 0-100,000ppm (10%)

10.1-4 Temperature Setup

- Both Reaction Chambers should be 50°C. \pm 1°C
- Both Photomultiplier Tubes should be 10°C. \pm 1 °C
- Oven - Nominally 190 °C. \pm 1 °C.
- Converter - NO2 Converter: Nominally 440°C. \pm 4°C.

NH3 Converter: 700°C. \pm 10 °C

10.1-5 Pressure Setup

Use values portrayed in S4interface main screen.

- **VACUUM** – 950 mbar minimum (the higher the better)
- **AIR** – 950 mbar
- **MAKEUP** – 600 mbar



10.2 System Specification

10.2-1 Detector

- Heated Chemiluminescence Detector (CLD)

10.2-2 Sample System

- Wetted materials:
 - 316 stainless steel
 - PTFE
 - Internal heated (191°C) oven
 - 0.4 micron PTFE sample filter, field replaceable

10.2-3 Heating

- Fully automatic

10.2-4 Safety

- The analyser has been constructed in accordance with prescribed safety standards. All hazardous circuits are shielded.

10.2-5 Power

- 600W (maximum warmup) at 100Vac – 250Vac. 24Vdc option available, 25A (maximum warmup)

10.2-6 Environment

- Ambient temperature 5°C to 40°C, relative humidity up to 95%, non-condensing

10.2-1 Zero Calibration Gas

- Use Nitrogen as a zero-calibration gas, ensure that the regulator and pipework supplying it to the analyser are clean and not contaminated.

10.2-2 Linearity

- Better than $\pm 2\%$ of point or $\pm 0.5\%$ FSD on all ranges down to 10% of range

10.2-3 Stability

- Drift: less than ± 0.2 ppm or $\pm 2\%$ of Range per 24 hours, whichever is greater

10.2-4 Noise

- Noise: less than ± 0.1 ppm or $\pm 1\%$ of range, whichever is greater

10.2-5 Response Time

- Less than 2 seconds (0% to 90%, 100% to 10%) at 2 l/min flow, range dependant. Applies to both rise and fall time.

DUE TO A POLICY OF CONTINUOUS DEVELOPMENT, THESE SPECIFICATIONS MAY CHANGE WITHOUT NOTICE



11 Table of Figures

Figure 1 : NOx Quasar Flow Scheme.....	14
Figure 2 : Quasar rear panel	15
Figure 3 : Quasar CLD pneumatic connections	16
Figure 4 : Quasar Filter Details	27
Figure 5 : Ozone Trap Cartridge Details.....	28
Figure 6 : Capillary access plate	30
Figure 7 : Quasar capillary locations	30
Figure 8 : Ozone Capillary Detail	31

12 Table of Tables

Table 1 : Document history table.....	2
Table 2 : Quick-start setup	10
Table 3 : Relay wiring table - Colours refer to Signal output cable MI/1020.....	21
Table 4 : Relay wiring table - Colours refer to Signal output cable MI/996.....	22
Table 5 : Chart Output Pinout Colour	23
Table 6 : Ardrex Information.....	26
Table 7 : Servicing frequency.....	29