

WWW.SIGNAL-GROUP.COM

ISSUE 4.2

AS80

CATALYTIC AIR PURIFIER INSTRUCTION MANUAL

SIGNAL GROUP LIMITED

12 DOMAN ROAD,

CAMBERLEY

SURREY, GU15 3DF

ENGLAND

SIGNAL

GROUP

E-MAIL: INSTRUMENTS@SIGNAL-GROUP.COM

INTERNATIONAL

TEL: + 44 (0)1276 682841

FAX: + 44 (0)1276 69302



DOCUMENT HISTORY

ISSUE	AMENDMENT	DATE
1	First Release	5/1986
2	ECN 941	9/1993
3	-	09/2007
4	ECN 2591	12/2020

© Signal Group Ltd.

All rights reserved. No part of this manual may be reproduced, stored in a retrieval system or transmitted in any form or by any means - electronic, mechanical, photocopying, recording or otherwise - without the prior written permission of Signal Group Ltd.

While we believe that the information and guidance given in this manual is correct, all parties must rely upon their own skill and judgment when making use of it. Signal Group Ltd. will not assume any liability to anyone for any loss or damage caused by any error or omission in the manual, whether such error or omission is the result of negligence or any other cause. Any and all such liability is disclaimed.

The information contained within this document is subject to change without notice.



1 Contents

2	Unpacking Instructions.....	5
3	Introduction.....	6
4	Installation.....	7
5	Operation.....	8
6	Maintenance.....	9
6.1	Instrument layout.....	9
6.2	Replacement of platinum catalyst.....	10
6.3	Replacement of molecular sieve/activated carbon.....	11



Read This First



Signal Group Ltd designs, manufactures and tests its products to meet many national and international standards. Because these instruments are sophisticated technical products, you **MUST** properly install, use, and maintain them to ensure they continue to operate within their normal specifications. The following instructions **MUST** be adhered to and integrated into your safety program when installing, using and maintaining Signal Group Ltd products. Failure to follow the proper instructions may cause any one of the following situations to occur: Loss of life; personal injury; property damage; damage to this instrument; and warranty invalidation.

- Read all instructions prior to installing, operating, and servicing the product.
- If you do not understand any of the instructions, contact your Signal Group Ltd representative for clarification.
- Follow all warnings, cautions, and instructions marked on and supplied with the product.
- Inform and educate your personnel in the proper installation, operation, and maintenance of the product.
- Install your equipment as specified in the Installation Instructions of the appropriate Instruction Manual and per applicable local and national codes. Connect all products to the proper electrical and pressure sources.
- To ensure proper performance, use qualified personnel to install, operate, update, program, and maintain the product.
- When replacement parts are required, ensure that qualified people use replacement parts specified by Signal Group Ltd. Unauthorised parts and procedures can affect the product's performance, place the safe operation of your process at risk, and **VOID YOUR WARRANTY**. Substitutions may result in fire, electrical hazards, or improper operation.
- Ensure that all equipment doors are closed, and protective covers are in place, except when maintenance is being performed by qualified persons, to prevent electrical shock and personal injury.



2 Unpacking Instructions

The Signal Model AS80 Catalytical Air Purifier is packaged for general freight purposes. It should withstand the occasional “bumps and knocks” which occur during transit.

Please check the instrument for damage, however, and report any damage within 24 hours to the factory or its Sales Office or Distributor.

- Before any connection is made, unscrew the 4 crosshead screws on instrument cover lid.
- Slide lid back to reveal the internal assemblies of the instrument. Note DO NOT take the cover off with power connected.
- Check that the temperature controller module is still secured well in its plug-in base. (This module is located on the right hand side of the instrument looking in from the front panel)
- Check for any loose or broken parts which may have occurred during transit.
- Slide lid back and re-do the screws (do this before connecting power).
- Please remove all packing around the instrument and remove the protective dust caps from the gas tube connections.
- Read through the rest of this manual thoroughly and then carry out the installation.



WARNING

Under no circumstances use any Halogenated Hydrocarbons, Silicone sprays, Polish, Silicone grease, Phosphorous compounds, leads (vapour or otherwise), leaded Gasoline Engine Exhaust, High Sulphur vapours or Aerosol spray cans containing Hybrid Hydrocarbons such as Freon, otherwise this may cause temporary or permanent damage to the Platinum catalyst.

3 Introduction

The Signal Model AS80 Catalytic Air Purifier is based on the principle of Catalytic Oxidation.

Alumina pellets coated in Platinum metal are fitted into a high temperature furnace. The high temperature together with the platinum noble metal oxidises all combustible compounds to CO₂ and H₂O. For practical purposes, the AS80 was developed for use with Hydrocarbons and Carbon Monoxide analysers. Both trace levels of Hydrocarbons (particularly CH₄) and Carbon Monoxide are extremely difficult to completely remove and this makes it difficult to obtain a reliable and inexpensive source of pure zero gas for these analysers.

The typical Flame Ionisation Detector (FID) based Hydrocarbon Analyser requires a continuous supply of zero grade air in order to support the flame in the detector. The air required for this flame should be sufficiently free of Hydrocarbons to provide a zero reference, and it should remain stable enough to eliminate any low level drift in the detector response.

The most difficult Hydrocarbon to remove is CH₄ (Methane) and it is this compound which is found mostly in ambient air (approx. 60%). No type of adsorption or absorption method effectively removes CH₄ but the high temperature platinum catalyst will remove CH₄ totally. (We have tested the Model AS80 up to 600 ppm CH₄ in Air at 5 L/min flowrate.)

Also the adsorption techniques have a finite saturation level and the higher the level of Hydrocarbons the quicker the adsorption chemicals need changing.

Thus the Signal Model AS80 Catalytic Air Purifier provides an inexpensive source of zero reference grade air and also gives a completely stable base line to the FID.



4 Installation

The Signal Model AS80 Catalytic Air Purifier is constructed in an instrument enclosure which is suitable for both 19" rack mounting or for bench top mounting.

When using this instrument in a 19" rack it is important to note that 500 Watts of heat are generated inside. This heat will need to be removed and particularly when being used next to an analytical apparatus.

The Signal Series 3000 or Solar Hydrocarbon Analyser is just such an instrument and when using the Model AS80 next to the analyser, ensure that the Model 3000 or Solar has at least 30 mm space above it before installing the Model AS80.

When using the Model 3000 or Solar on a bench always ensure that UNDER NO CIRCUMSTANCES the AS80 be left to rest on the analyser top.

The tube inlet is a 1/4" OD stainless steel tube welded into the Furnace body. Use a 1/4" to 1/4" compression fitting to connect to the main Air inlet supply.

When using air which is saturated with water, the built in molecular sieve will need to be changed very frequently. In order to prevent this, it would be better to fit a coalescing water trap and reducing valves (see Figure 1 : AS80 Installation schematic).

In this configuration the compressor will raise the air pressure to approximately 8 bar and all the water vapour beyond the dewpoint (at eight bar and ambient temperature) will form into droplets in the coalescent water trap. After this water trap the gas is reduced to 5 bar pressure and, of course, this raises the saturation point of the water in Air. Therefore, any further water generated by the oxidation in the furnace will not produce water droplets in the tube and further reduction in pressure to 2 bar will remove water droplets entirely.

Please contact your local Signal-Group representative for additional support.

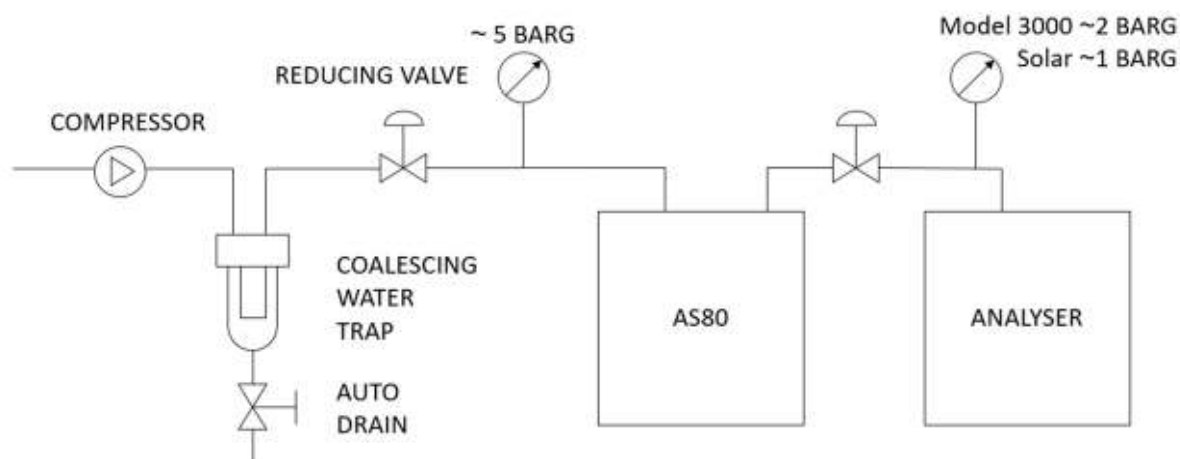

Figure 1 : AS80 Installation (100614)



5 Operation

Having connected the Model AS80 to the recommended schematic, plug the mains power cable into a suitable earthed (grounded) socket capable of supplying 220V 5 Amperes. Switch on the unit on the mains power switch on the front panel and leave 1 hour to warm up.

The unit is now ready to supply pure air at a maximum of 5 L/min. If more than 5 L/min is taken through the unit the higher mass of Air will remove the heat quicker than the furnace can supply it and this reduction in heat will result in a reduction in the furnace's capability to remove all the Methane (CH₄) although up to 15 L/min can be tolerated if only Non-Methane Hydrocarbons (i.e. Propane etc.) are present.

Tests having been performed by our Laboratories suggest that there is no degradation in performance at up to 600 ppm of Methane.



6 Maintenance

If for any reason you wish to replace the platinum catalyst, please order a fresh pack of catalysts from your Signal Sales Office. Specify part No. AS80 1001.

If for any reason you wish to replace the Molecular Sieve/Actuated carbon specify recharge pack No. AS80 1002.

6.1 Instrument layout

The Instrument is laid out inside with the Platinum catalyst furnace being the first part of the flow scheme. The clean air passes out of this furnace through a cooling coil and through a further trap containing molecular sieve, actuated carbon and a fibreglass filter.

The molecular sieve/actuated carbon is to remove water vapour and NO_x and this trap should be recharged approximately after 2500 hours of use. The platinum catalyst (which is the main part of this instrument) does not require recharging unless it becomes poisoned.

See WARNING note at the beginning of this manual.

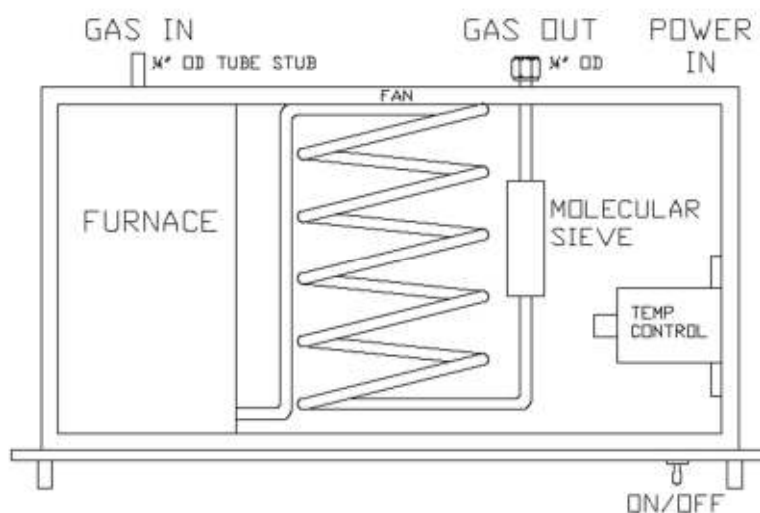

Figure 2 : Instrument layout diagram



6.2 Replacement of platinum catalyst

WARNING - Disconnect the mains cable before attempting this procedure.

- Remove top panel.
- Remove bottom panel.
- Remove stop.
- Remove front panel screws and drop the panel forward.
- Disconnect the heater wires at the terminal block.
- Disconnect the thermocouple wires on pins 5 and 7 of the controller base.
- Loosen the securing clamps around the oven assembly. Disconnect the cooling coil from the oven assembly at the in-line fitting.
- Slide the oven assembly forward through the front panel opening.
- Remove the four fixing screws on the outer tube at the thermocouple/heater termination end of the oven and remove the retainer.
- Withdraw the barrel. Remove and retain the insulation material.
- Secure the barrel in a vice gripping only the centre of the barrel and unscrew the tube inlet cap. Do not hold the end with the heater termination or attempt to remove it.
- Remove and discard the carbon gasket from the end cap.
- Carefully remove and retain the stainless steel mesh from inside the barrel. Shake out and discard the pellets.
- Taking the recharge pack, AS80/1001, fill the barrel with the new pellets to about 60mm from the barrel end. Do this in several stages, lightly tapping the barrel to settle the pellets.
- Carefully re-pack the stainless-steel mesh so that all the free space above the pellets and around the heater element is completely filled. Do not let the mesh overlap the end of the barrel.
- Use a high temperature anti-galling compound on the barrel thread. A suitable compound is our part number MI/124.
- Position the replacement carbon gasket over the barrel edge and fit the end cap over the barrel.
- Tighten by hand until the end cap grips the gasket, then tighten with a spanner a further 30 degrees.
- Pressurise the assembly and check for leaks.
- Wrap the insulating material around the barrel and end caps and slide into the outer tube. Refit the retainer.
- Re-assemble the instrument.
- Alternatively, replacement oven assemblies are available. Ask for part number 103001.



6.3 Replacement of molecular sieve/activated carbon

WARNING - Disconnect the mains cable before attempting this procedure.

- Remove top panel.
- Identify the compression fitting at the rear end of the trap

DO NOT REMOVE THIS FITTING.

- Disconnect the ¼” tube fitting at the rear panel bulkhead. Disconnect the ¼” tube fitting at the oven outlet (junction with cooling coil), and remove the filter/coil assembly.
- Clamp the compression fitting at the coil end in a bench vice.
- Loosen the nut and remove the assembly from the vice. Do not break the seal where the cooling coil meets the compression fitting.
- Remove the cooling coil, complete with fitting, from the assembly.
- Remove the mesh retainer and empty out the contents.
- Using the recharge pack, AS80 1002, refill the container first with the molecular sieve and mesh retainer, then with activated carbon and mesh retainer.
- Refit the cooling coil. Only tighten the fitting by clamping the fitting base in a vice and ensuring that a strain is placed on the junction with the cooling coil.
- Reassemble into the unit.
- Alternatively, replacement oven assemblies are available. Ask for part number 103020.