

200SM SERIES COOLER DRYER OPERATING MANUAL

The SIGNAL INSTRUMENT Co. Ltd.

12 Doman Road, Camberley

Surrey, GU15 3DF

England

Tel: +44 (0) 1276 682841

Fax: +44 (0) 1276 691302

Part Number 200/334050

DOCUMENT HISTORY

ISSUE	AMENDMENT	DATE
1.00	First Issue	December 3, 1996
2.00	Fuse Change Page 9	February 19, 1998
2.01	Addition of Warranty Statement	October 6, 1998

© The Signal Instrument Co. Ltd.

All rights reserved. No part of this manual may be reproduced, stored in a retrieval system or transmitted in any form or by any means - electronic, mechanical, photocopying, recording or otherwise - without the prior written permission of The Signal Instrument Co. Ltd.

While we believe that the information and guidance given in this manual is correct, all parties must rely upon their own skill and judgement when making use of it. The Signal Instrument Co. Ltd. will not assume any liability to anyone for any loss or damage caused by any error or omission in the manual, whether such error or omission is the result of negligence or any other cause. Any and all such liability is disclaimed.

CONTENTS

1. INTRODUCTION	7
1.1 Cooler.....	7
1.2 Applications.....	7
1.3 Getting Started.....	7
1.4 Special Requirements.....	7
2. SPECIFICATION	8
2.1 Sample Heat Removal.....	8
2.2 Sample Input	8
2.3 Sample Outlet.....	8
2.4 Response time.....	8
2.5 Peristaltic Pump	8
2.6 Environment.....	8
2.7 Options	9
2.8 Power.....	9
2.9 Analogue Outputs	9
2.10 Alarm Limits	9
2.11 Alarm Relay.....	9
2.12 Physical Dimensions.....	9
2.13 Sample Path.....	9
2.14 Safety	10
3. INSTALLATION.....	11
3.1 Introduction	11
3.2 Channel Variants	11
3.3 Typical Application Configurations.....	11
3.4 Basics	12
3.5 Location.....	13
3.6 Rack Mounting.....	13
3.7 Mains Power Connections.....	13
3.8 Gas Connections	14
3.9 Water Drain	15
3.10 Alarm Relay.....	15
3.11 Alarm Connections	15
4. BASIC OPERATION	16
4.1 Introduction	16
4.2 Installation.....	16
4.3 Start Up	16
4.4 Shut Down.....	16
5. OPERATION	17
5.1 Introduction	17
5.2 Description.....	17
5.3 Alarm Conditions	18
5.4 Using The Alarm Relay	18
5.5 Controlling Signal Analysers	18
5.6 Remote Temperature Monitoring.....	19
6. TROUBLE SHOOTING.....	20
6.1 Intermittent Water Alarm.....	20
6.2 Output Dew Point Deviations	20
6.3 Sample Dew Point.....	20

7. TECHNICAL DESCRIPTION	22
7.1 Description.....	22
7.2 Peltier Cooling Elements.....	22
8. ROUTINE MAINTENANCE	23
8.1 Catch Pot Water Removal.....	23
8.2 Peristaltic Pump Tube Replacement	23
8.3 Fuse Replacement	24
8.4 Spares Kit	24
9. ROUTINE SERVICING.....	25
9.1 Policy.....	25
9.2 Servicing	25
9.3 Spares Kit	25
10. WARRANTY	26

Tables

Table 1 Fuse and VA Rating.....	9
---------------------------------	---

Figures

Figure 1 Channel Performance.....	8
Figure 2 Typical CEM Configuration	11
Figure 3 Typical Automotive Configuration.....	11
Figure 4 Sample Heat Content.....	12
Figure 5 Channel Performance.....	13
Figure 6 Rear Panel Layout.....	14
Figure 7 Alarm Connector.....	15
Figure 8 Front Panel Controls and Indicators	17
Figure 9 Upstream Pump Control.....	18
Figure 10 Downstream Solenoid Control.....	18
Figure 11 Controlling a Signal Analyser.....	18
Figure 12 Sample Dew Point Estimation.....	21
Figure 13 Peristaltic Tube Connections.....	23
Figure 14 Flow Diagram (3 Channel).....	24



1. INTRODUCTION

1.1 Cooler

- 1.1.1 The 200SM series of rack mounted coolers are based on the solid state Peltier element and include a continuous peristaltic drain pump. The coolers are available with one, two, or three independent channels.
- 1.1.2 A conditioned sample with a dew point of 5 °C can be obtained from a hot sample gas of up to 210 °C and having a dew point of up to 70 °C.
- 1.1.3 Water and dual temperature alarms, and a temperature monitor output are a standard feature for each channel.

1.2 Applications

- 1.2.1 These cooler dryers are used to provide a conditioned sample to those analysers not having a heated sample system, or where they are susceptible to cross interference from water vapour.

1.3 Getting Started

- 1.3.1 Installation.
 - 1.3.1.1 Unless you are familiar with the installation of gas coolers, we recommend that you read section 3 from start to finish.
- 1.3.2 Operation
 - 1.3.2.1 Read all of section 4 for the minimum steps necessary to get your cooler working. Then read all of section 5 to learn more about the cooler.
- 1.3.3 Maintenance
 - 1.3.3.1 Read the section 8 to keep your cooler in first class condition.

1.4 Special Requirements

- 1.4.1 Location
 - 1.4.1.1 The cooler transfers heat from the sample to the local ambient air. Cold air is taken from local ambient at the front, top, and sides; heat is transferred to it and it is vented out from the rear of the cooler. The colder the local ambient air, the more efficient the cooler performance. The hot air must not be allowed to recirculate back to the cooler. Read the installation section carefully.
- 1.4.2 Sample flow
 - 1.4.2.1 The sample must be passed through the cooler.. This is best achieved with an upstream heated pump and bypass control system.
 - 1.4.2.2 Best results and reliable performance are achieved when the sample is pulse free.
- 1.4.3 Sample filter
 - 1.4.3.1 A particulate filter should be fitted before the cooler.

2. SPECIFICATION

2.1 Sample Heat Removal

2.1.1 Maximum 18 W per channel at 25 °C ambient.

2.1.2 Figure 1 shows the maximum cooling capability for each channel over the ambient temperature range.

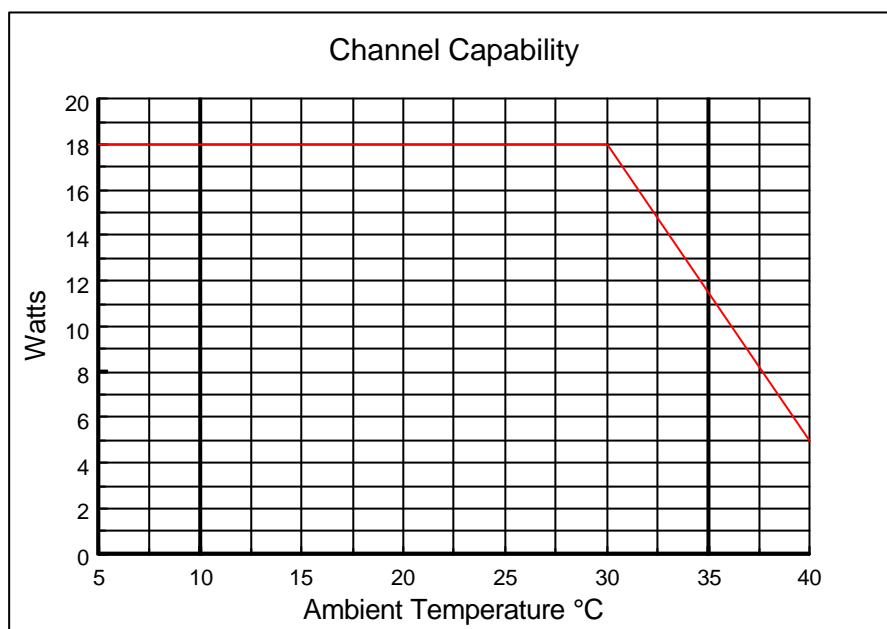

Figure 1 Channel Performance

2.2 Sample Input

2.2.1 Maximum inlet temperature 210 °C.

2.2.2 Maximum dew point 70 °C.

2.2.3 Single port feeds all channels. ¼" tube fitting.

2.2.4 Inlet Pressure -5 psig to +15 psig.

2.3 Sample Outlet

2.3.1 Up to three output channels

2.3.2 Output Dew Point +5 °C ±0.5 °C non adjustable.

2.3.3 ¼" tube fitting per channel.

2.3.4 Maximum 3 l/min per channel.

2.3.5 Pressure difference input to output < 0.2 psig (6" WG) at 2 l/min, 190 °C, and 50 % dew point sample.

2.4 Response time

2.4.1 All channels will be ready for use within 30 minutes of switch on with no sample flowing.

2.5 Peristaltic Pump

2.5.1 Maximum Pressure at outlet into which it will pump is 5 psig.

2.6 Environment

2.6.1 Ambient Temperature +5 °C to 40 °C.

2.6.2 Relative Humidity to 95 % non-condensing

2.6.3 Keep out of direct sunlight and other forms of radiant heat.

2.7 Options

2.7.1 Available in 1, 2, or 3 channel versions.

2.7.1.1 201SM - Single Channel.

2.7.1.2 202SM - Dual Channel.

2.7.1.3 203SM - Triple Channel.

2.7.2 The version is marked on the serial number on the rear panel.

2.8 Power

2.8.1 Dual voltage 115 Vac \pm 15% or 230 Vac \pm 15% selectable from the rear panel.

2.8.2 Mains fuse sizes are all 5 x 20 mm. HBC

Channels	1		2		3	
Supply	115 Vac	230 Vac	115 Vac	230 Vac	115 Vac	230 Vac
VA	180	180	270	270	360	360
Fuse	4 AT	3.15AT	6.3 AT	3.15 AT	6.3 AT	3.15 AT

Table 1 Fuse and VA Rating

2.9 Analogue Outputs

2.9.1 Non-isolated voltage outputs proportional to channel temperature in the range 0 - 50 °C. 100 mV represents 1 °C. Accuracy \pm 0.7 °C over the range.

2.9.2 Continuous short circuit allowed. Recovery < 15 min.

2.10 Alarm Limits

2.10.1 High

2.10.1.1 Channel temperature > 5 °C above the control temperature.

2.10.2 Low

2.10.2.1 Channel temperature < 1 °C below the control temperature.

2.10.3 Water

2.10.3.1 Alarm when there is more than 20 mL of static water in the catch pot.

2.11 Alarm Relay

2.11.1 Volt free dual change-over relay contacts with the de-energised state representing the alarm condition.

2.11.2 Contact ratings 1 A at 50 Vdc.

2.11.3 Isolation > 10 M Ω at 50 Vdc.

2.12 Physical Dimensions

2.12.1 Rack mounting 5U high (222.3 mm, 8 $\frac{3}{4}$.)

2.12.2 Depth in front of mounting face 45 mm.

2.12.3 Depth behind mounting face 533 mm.

2.12.4 Weight 10 kg + 5 kg per channel.

2.13 Sample Path

2.13.1 Materials in contact with the sample are :-

2.13.1.1 316 Stainless Steel

2.13.1.2 PTFE

2.13.1.3 PVDF

2.14**Safety**

2.14.1

The cooler has been constructed in accordance with prescribed safety standards. All hazardous circuits are shielded.

3. INSTALLATION

CAUTION

THE COOLER MUST NOT BE USED WITHOUT A SAFETY EARTH CONNECTION.

After connection to a source of hot sample, the inlet port may become hot.

TAKE PRECAUTIONS AGAINST BURNS.

3.1 Introduction

3.1.1 Installation requires the use of a tool set compatible with electrical and pneumatic skills. A suitable set of tools for a minimum installation consists of an electrician's flat bladed screwdriver for the mains connections, a sharp knife for cutting PTFE tubing, a $\frac{9}{16}$ " (14.3 mm) A/F spanner for $\frac{1}{4}$ " fittings. Full installation of chart recorder, and other features may require the use of a soldering iron plus solder, wire cutters, wire strippers, small pliers, and a working knowledge of the equipment to be connected. Plumbing in stainless steel will require the use of pipe cutters and benders. We, or our local agents, can offer an installation service if you do not have the necessary skills.

3.2 Channel Variants

3.2.1 A single channel cooler uses channel 1

3.2.2 A dual channel cooler uses channels 1 and 3.

3.2.3 In a three channel cooler, use channel 2 for the analyser requiring the lowest sample flowrate.

3.3 Typical Application Configurations

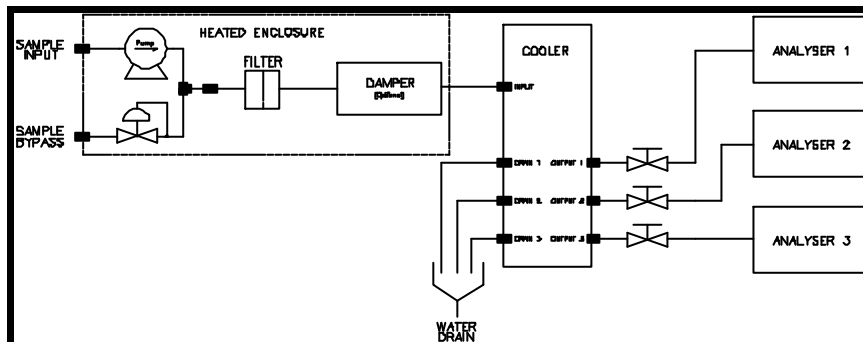

Figure 2 Typical CEM Configuration

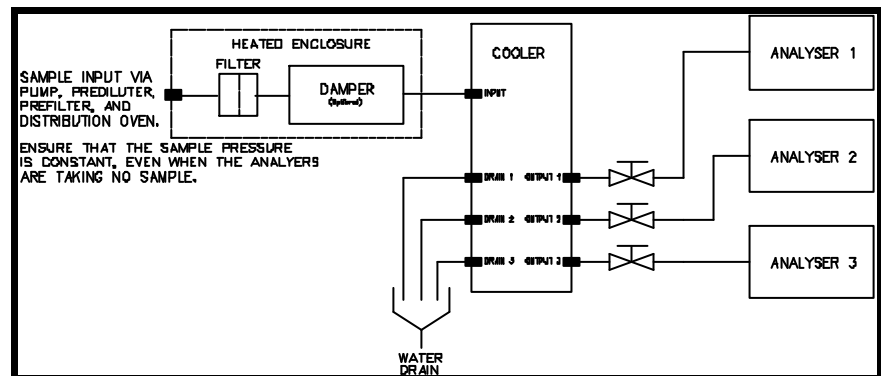

Figure 3 Typical Automotive Configuration

3.4 Basics

- 3.4.1 Cooler performance is a compromise between installation environment and sample condition.
- 3.4.2 The ambient temperature surrounding the cooler sets an upper limit to the amount of heat that can be extracted from the sample.
- 3.4.3 The amount of heat to be removed is a function of the sample dew point and temperature, and the rate of heat removal is directly proportional to flow rate.
- 3.4.4 Estimate the heat extraction rate required to cool 1 L/min sample using Figure 4 and calculate total rate for each channel by multiplying by the required flow rate..

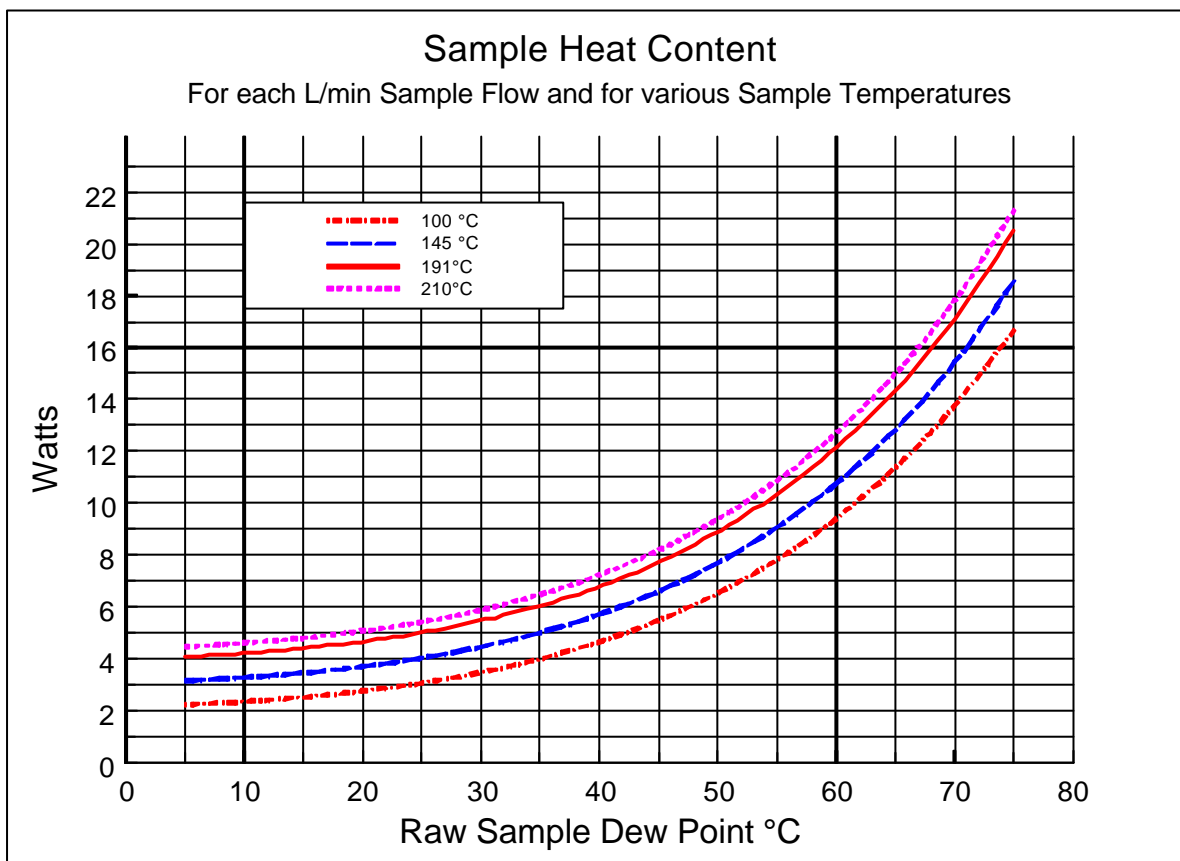

Figure 4 Sample Heat Content

- 3.4.5 From the performance graph in Figure 5 determine the maximum ambient temperature allowed for this performance.
- 3.4.6 In severe cases it may be necessary to provide air conditioning for the cooler to reduce the ambient temperature or to add another cooler to spread the load. Refer to section 3.8.2 for using two or three channels to supply one analyser.

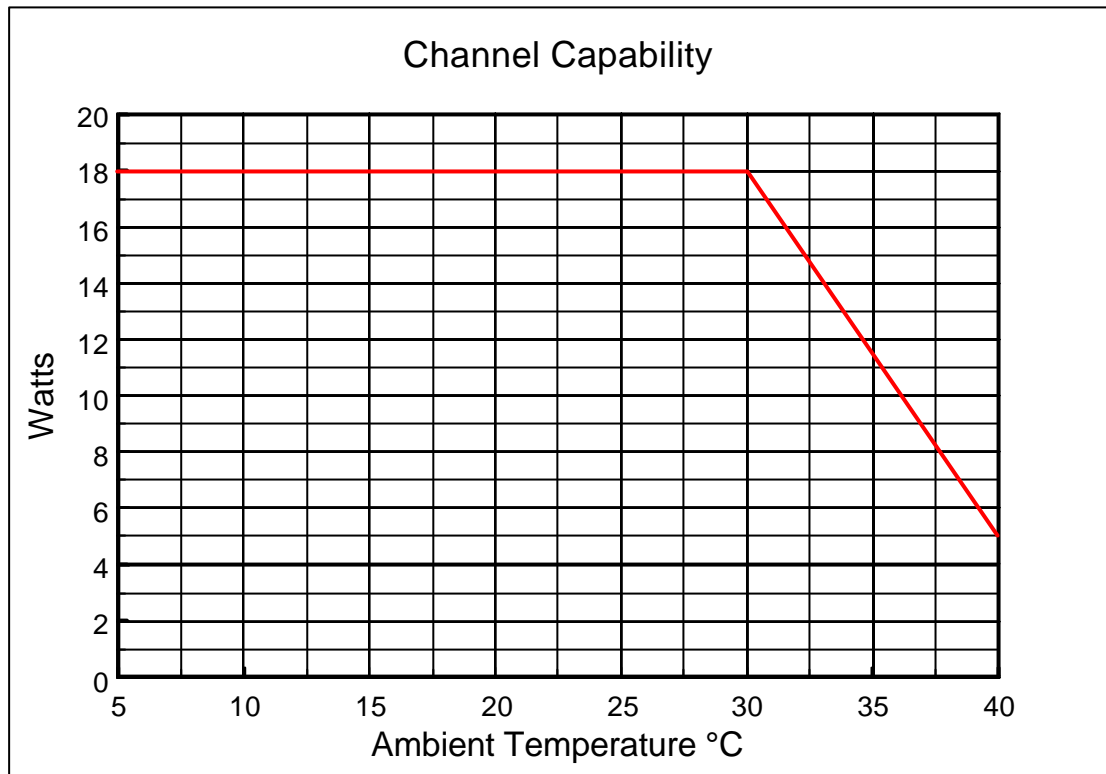

Figure 5 Channel Performance

3.5

Location

- 3.5.1 The cooler can be bench or rack mounted and should be placed in a dry and sheltered location out of direct sunlight, with good ventilation, and protected from water ingress.
- 3.5.2 Observe the environmental limitations listed in the specification section.
- 3.5.3 The cooler must have a source of ambient temperature air around the front, sides, top and bottom. It vents hot air from the back. This hot air must be extracted and not allowed to recirculate back to the cooler.

3.6

Rack Mounting

- 3.6.1 Unscrew the four feet and retain in a safe place prior to rack mounting. Plastic buttons on the outside edge of the base provide a 'gliding' surface when using rack supports.
- 3.6.2 All Signal analysers and the 200SM coolers exhaust hot air from the rear. When rack mounting, allow a 1U gap above and below the cooler. Ensure that there is a supply of ambient air at the front and sides and that the column of hot air at the back of the rack is extracted and vented away from the air inlet areas. It may be necessary to provide air conditioning for a rack mounted system if it would cause the local ambient inside the rack to exceed the environmental limitations of the cooler.

3.7

Mains Power Connections

- 3.7.1 Mains Voltage
 - 3.7.1.1 Check your local mains voltage. It must fall inside the $\pm 15\%$ limits of the nominal 115 Vac or 230 Vac settings of the mains selector switch.

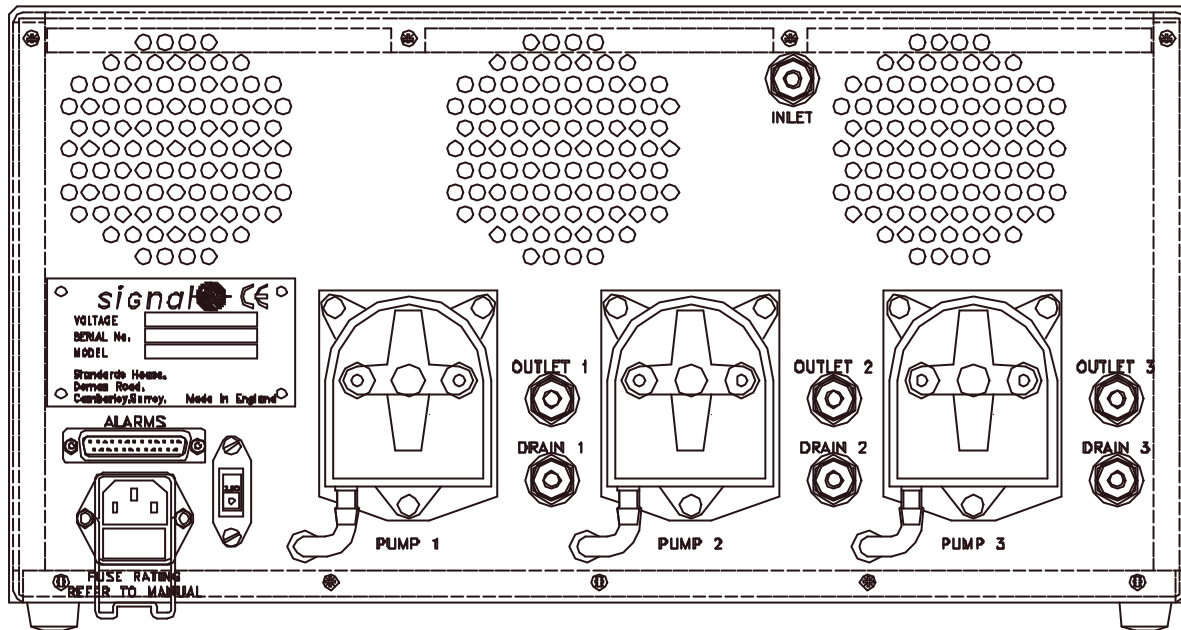

Figure 6 Rear Panel Layout

- 3.7.1.2 Set the switch to the corresponding setting and check that the fuse ratings and types fitted comply with those given in section 2.8. A spare set of fuses is supplied in the accessory kit.
- 3.7.2 Wiring
 - 3.7.2.1 The mains lead supplied with the analyser is colour coded and must be connected according to the following instructions to make the cooler safe for use.
 - 3.7.2.1.1 Connect the BROWN wire to the LIVE (L) pin of the mains plug.
 - 3.7.2.1.2 Connect the BLUE wire to the NEUTRAL (N) pin of the mains plug.
 - 3.7.2.1.3 Connect the GREEN/YELLOW wire to the EARTH (E) pin of the mains plug.
 - 3.7.2.2 Earthing
 - 3.7.2.2.1 The cooler must be used with a safety earth. If your mains supply has no earth terminal, a separate earth must be connected to the M6 stud on the rear panel. This stud can be used to provide a common ground or screen when data logging. Consult a qualified electrician if you have no earth at all.
 - 3.7.2.3 No Local Earth
 - 3.7.2.3.1 If the local mains supply does not provide an earth connection, you must supply an independent one. Consult a qualified electrician.
 - 3.7.2.3.2 A mains distribution panel should be installed to provide earthed power outlets for the cooler and all associated equipments. You may wish to include extra facilities for data recording or computer facilities at the same time.

3.8 Gas Connections

- 3.8.1 Input
 - 3.8.1.1 The input must be filtered to prevent accumulation of particulate within the cooling channels.

- 3.8.1.2 The input should also be pressurised, within the limits in the specification, to create flow through each channel. The flow should be pulse free to prevent water carry-over. The possibility of water carry-over is increased if down stream pumping is used.
- 3.8.1.3 An input bypass must be provided so that the inlet pressure is controlled if all analysers are switched off or are calibrating and not using sample gas. Automotive applications normally have an up-stream heated sample pump with a bypass control and prefilter as part of the sample system. CEM applications will need at least a heated pump and bypass regulator. You can purchase standard parts from us if you wish. Contact our sales department.
- 3.8.1.4 Connect the sample source to the ¼" fitting labelled **INPUT**.
- 3.8.2 **Output**
- 3.8.2.1 Each channel has its own output. Use one channel per analyser and control the flow using a needle vale or other restriction. The output flow must be set to a level compatible with the ability of the cooler to remove heat from the sample at that flow rate and at the local ambient temperature. Refer to the performance graphs.
- 3.8.2.2 **DO NOT JOIN THE OUTPUTS DIRECTLY TOGETHER.**
- 3.8.2.3 If you cannot get sufficient flow through a single channel, two or more channels can be joined **AFTER** the flow control valves. The flow in each channel must be individually controlled with equal flows in each.

3.9 Water Drain

- 3.9.1 Condensate from the sample is removed by a peristaltic pump on the rear panel. The condensate may be acidic and should be treated as hazardous waste in accordance with your local regulations. Typical contents could include Nitric Acid, Nitrous Acid, Sulphurous Acid, Sulphuric Acid, Carbonic Acid. Ensure that all pipe work and fittings used to route the water to a safe dump point are resistant to these acids and any others that could be produced when your sample gas comes into contact with water.
- 3.9.2 The outlet of the peristaltic pump should not be restricted.
- 3.9.3 Connect silicon or other suitable tubing to the outlet (nozzle to the right of the pump and attached to the pump tube) of each peristaltic pump and route to the drain point.
- 3.9.4 It is important that the drain point is insulated against ambient temperature to protect against freezing. This would block the pipe and prevent water removal.

3.10 Alarm Relay

- 3.10.1 Each channel has an independent alarm relay. The relay has two independent change-over contact sets available on the rear panel. The contacts are only rated for low power (refer to section 2.11) and must be used with an auxiliary relay to control mains operated or high power devices.

3.11 Alarm Connections

- 3.11.1 All channel outputs are on the same connector. It is important to preserve the EMC compliance by using the connector supplied in the accessory kit with a suitable braided cable. The cable braid must have a continuous connection between the cooler and the measurement or control equipment. A screened junction box will be necessary if the cable is to be split to serve multiple outlets.
- 3.11.2 Figure 7 shows the connector pin identification.

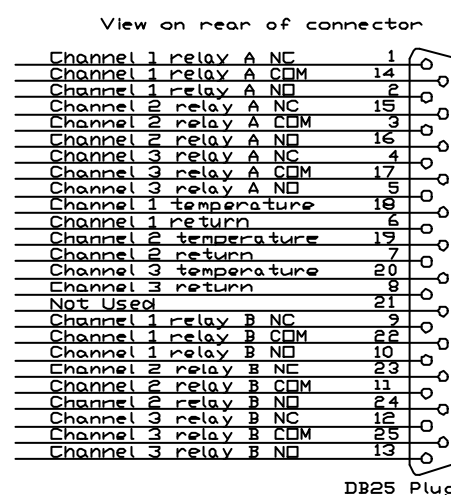

Figure 7 Alarm Connector

4. BASIC OPERATION

4.1 Introduction

- 4.1.1 The following instructions guide you through the steps necessary to achieve sample cooling.
- 4.1.2 The cooler has no controls other than the mains on-off switch making it a very simple device to use.
- 4.1.3 It is very important that the installation section is read and understood before using the cooler. The location, environment, and sample conditions all affect the performance and must be taken into account if a consistent and reliable performance is to be obtained.

4.2 Installation

- 4.2.1 Install the cooler in accordance with section 3 ensuring that the environmental conditions are met and that the mains selector switch has been set to suit your local mains supply.

4.3 Start Up

- 4.3.1 Ensure that there is no sample flow to the analysers. One way is to set all analysers to measure a 'ZERO' gas.
- 4.3.2 Operate the front panel mains switch and observe the power indicator glowing for each fitted channel. Wait for the READY indicator on each fitted channel to glow.
- 4.3.3 The cooler is now ready for use. Select 'SAMPLE' on each analyser and cool, de-humidified sample will be supplied.

4.4 Shut Down

- 4.4.1 Turn off the sample flow to each analyser. Turn the mains power switch off.

5. OPERATION

5.1 Introduction

5.1.1 This section gives a detailed explanation on the use and operation of the cooler.

5.2 Description

5.2.1 The cooler is contained in a 5U case suitable for bench or rack mounting. All pneumatic and electrical connections are on the rear panel. The front panel contains channel indicators and the mains power switch.

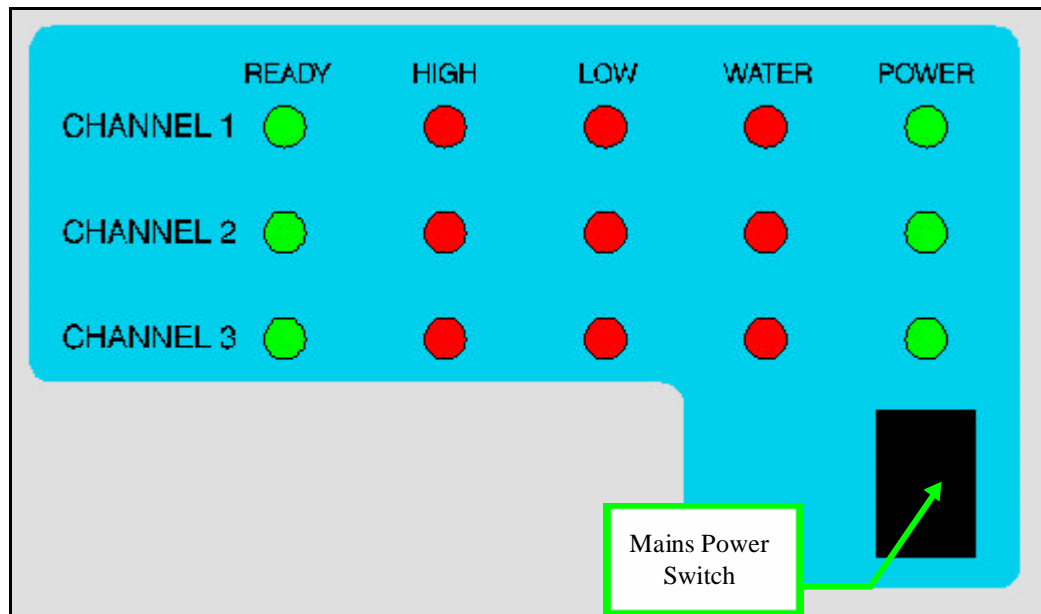

Front Panel Controls and Indicators

- 5.2.2 A single input from your hot sample connects to the inlet port on the rear panel. The sample is internally distributed to one, two, or three channels depending on the model. The model number is on the serial number plate on the rear panel. Once power is connected and the cooler switched on, you can tell from the state of the front panel POWER indicators how many channels are fitted.
- 5.2.3 A single channel version uses channel 1. A dual channel version uses channels 1 and 3.
- 5.2.4 Indicators
- 5.2.4.1 There is a row of indicators on the front panel showing the status of each channel. When the cooler is switched on, the **POWER** indicator on each channel fitted will glow. Indicators coloured RED warn that the channel is not available for use.
- 5.2.4.2 **READY** glowing means that the channel is ready to use.
- 5.2.4.3 **HIGH** glowing means the temperature is too high and that the channel is not ready for use.
- 5.2.4.4 **LOW** glowing means the channel temperature is abnormally low and indicates a possible problem. An abnormally low temperature could result in freezing any residual water in the chamber and causing a blockage. Turn off the sample flow to any channel showing this condition.
- 5.2.4.5 **WATER** glowing means that water from the chamber has been ejected into a safety 'catch pot' due to abnormal sample pressure surges. Immediately turn off the sample flow to any channel showing this condition to prevent water carry-over into the analyser. Refer to section 8 for instructions on clearing the catch pot.

5.3 Alarm Conditions

5.3.1 The appearance of any RED indicator on a channel’s status display will activate an internal relay. The relay has two independent change-over contact sets available on the rear panel. The contacts are only rated for low power and must be used with an auxiliary relay to control mains operated devices.

5.4 Using The Alarm Relay

5.4.1 The relay contacts can be use to sound a warning alarm and to automatically switch the sample pump off, or to set Signal Series III analysers to their standby states. Take care not to exceed the relay contact ratings. An auxiliary relay will be required if you are driving mains loads or other high voltage, high current devices.

5.4.2 Upstream Pump Control

5.4.2.1 The alarm relay can be used to control an upstream pump so that it will stop if an alarm condition exists. A latching relay with a bush-button start is required. If sufficient damping can be provided so that pressure pulses do not occur when the pump starts or stops, the latching relay may not be necessary.

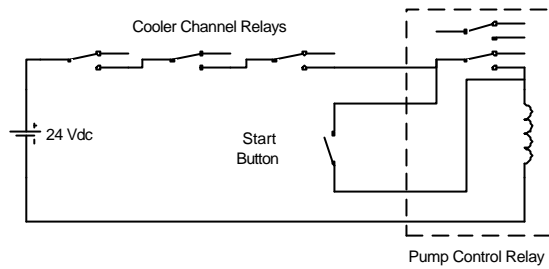

Figure 9 Upstream Pump Control

5.4.2.2 Connect all normally open contacts from each channel in series. When an alarm condition exist, the pump will be automatically turned off.

5.4.3 Analyser Valve Control

5.4.3.1 The alarm relay for a particular channel may be used to control a downstream solenoid valve so that there is no flow to an analyser when an alarm condition exists. There should be sufficient damping in the system so that operating the solenoid valve does not cause significant pressure pulses.

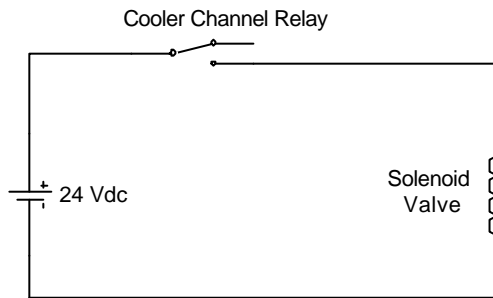

Figure 10 Downstream Solenoid Control

5.4.3.2 Connect the normally open contacts for one channel in series with the control valve for that channel. The valve will close whenever an alarm condition exists.

5.5 Controlling Signal Analysers

5.5.1 All Series III analysers have a remote ‘SLEEP’ control activated by a contact closure. This places the analyser into standby mode after purging the measurement path with zero gas. It is important that the plumbing includes sufficient damping to prevent significant pressure pulses.

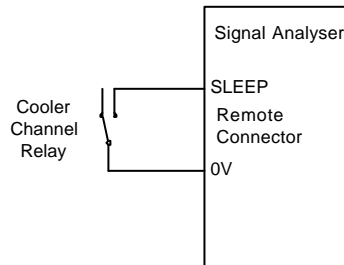

Figure 11 Controlling a Signal Analyser

- 5.5.2 Connecting one of the relay change-over contacts to these inputs will ensure that the analyser does not take sample until the cooler is switched on, has reached temperature, and no error conditions exist. Refer to the operating manual supplied with the analyser.

5.6 Remote Temperature Monitoring

- 5.6.1 Each channel has an independent buffered voltage output available on the rear panel for the remote monitoring of channel temperature. Each output is referenced to the local ground. It can be connected to most data logging or chart recording devices. The output is a nominal 100 mV/°C and covers the range 0 °C to +40 °C.

6. TROUBLE SHOOTING

6.1 Intermittent Water Alarm

6.1.1 This could be due to too high a sample flow rate or to flow pressure pulsations. Turn off the sample flow. The light should be either on or off. In either case, drain the catch pot as detailed in section 8.1. If the light is still intermittent, the cooler should be returned for repair.

6.1.2 It requires an abnormal situation for water to get as far as the catch pot. Check that the sample flow rate is within specification. Check that there are no large pressure pulses in the sample flow - in particular when the analyser switches from "sample" to "calibrate" and back again. In extreme cases it may be necessary to insert a damping volume either upstream or in each downstream path of the cooler.

6.2 Output Dew Point Deviations

6.2.1 Although the set point temperature is +5 °C, the control temperature, and hence the dew point, can climb to +10 °C before giving warning of a high temperature. Excursions above the set point occur when the cooler is attempting to extract more heat from the sample than it can at the local ambient temperature. Try reducing the flow rate through that channel. The amount of heat extracted is proportional to flow rate. Check that your ambient temperature is within limits.

6.2.2 If the control temperature is at 5 °C but a dew point meter gives a higher measurement, there may be water in the catch pot re-humidifying the sample as it leaves the cooler. This will be more noticeable in high ambient temperature conditions. Drain the catch pot (refer to section 8.1). This will not remove all the water. The remaining water will gradually evaporate with time and the dew point return to its correct level.

6.3 Sample Dew Point

6.3.1 An approximation for the sample dew point can be determined experimentally by collecting the water from one chamber's water dump. Set the flow rate in that channel to 1 L/min and collect the water for one hour. Look up the equivalent dew point for that volume of water in Figure 12.

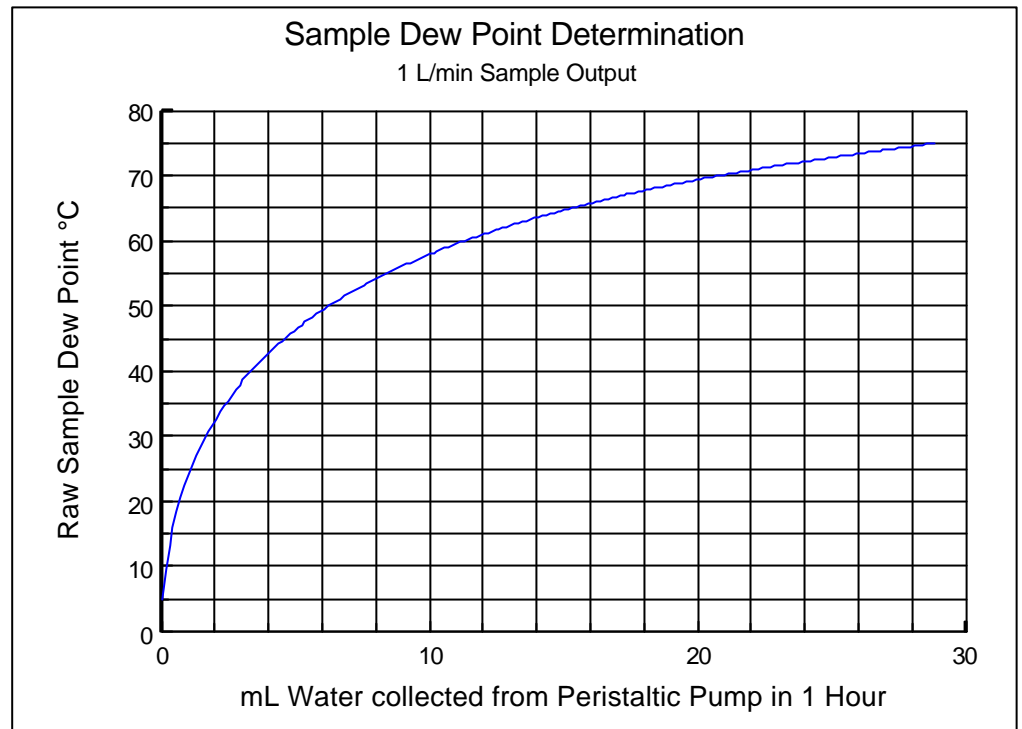

Figure 12 Sample Dew Point Estimation

7. TECHNICAL DESCRIPTION

7.1 Description

7.1.1 The cooler consists of up to three channels of fan assisted solid state, peltier element cooling with associated electronics. A pre-cooling coil in the forced air cooling path preconditions the sample. The pre-cooled sample is fed to a sample chamber where a labyrinth surrounds a cold block held at the control temperature. Water is collected at the bottom of the labyrinth and removed using a peristaltic pump. The sample exits the chamber and passes through a catch pot. The catch pot provides a safety mechanism for situations where a pulsing sample flow produces turbulence in the chamber which forces water out. A water alarm indicates a build up of water in the catch pot.

7.1.2 A thermistor sensor detects the cold block temperature. The output from a bridge containing the thermistor is compared with a reference and used to control the current through the peltier element. A constant current drive is used to improve the thermal efficiency.

7.2 Peltier Cooling Elements

7.2.1 Peltier Effect Definition.

7.2.1.1 When an electric current flows across the junction between two different metals or semiconductors, a quantity of heat, proportional to the total electric charge crossing the junction, is evolved or absorbed, depending on the direction of the current. This effect is due to an electromotive force at the junction. Named after Jean Peltier (1785 - 1845).

7.2.2 In practice, a large number of junctions connected in series and/or parallel are arranged mechanically to 'pump' heat from one side of the assembly to the other.

7.2.3 The cold side is mechanically coupled to a large aluminium block which is used as a 'surface' against which the sample gas can be cooled. The hot side is mechanically coupled to a large finned heatsink over which cool ambient air is forced to transfer the heat to the outside world.

7.2.4 As with most electro-mechanical, effects the process is inefficient. Passing a current through the multiple junctions creates its own heat from resistance losses. Thus the total heat to be removed is always greater than the heat removed from the sample. The maximum amount of heat that can be removed depends on the temperature difference between the hot and cold surfaces. The cold temperature is fixed - it is the required 5 °C dew point. The hot side depends on the gradient across the heatsink necessary to remove all the heat. The higher the ambient temperature, the greater the temperature difference and the less efficient the heat transfer process.

7.2.5 The design of the 200SM series coolers is a compromise between the working ambient temperature and the rate of heat removal and results in the performance graphs given in earlier sections.

8. ROUTINE MAINTENANCE

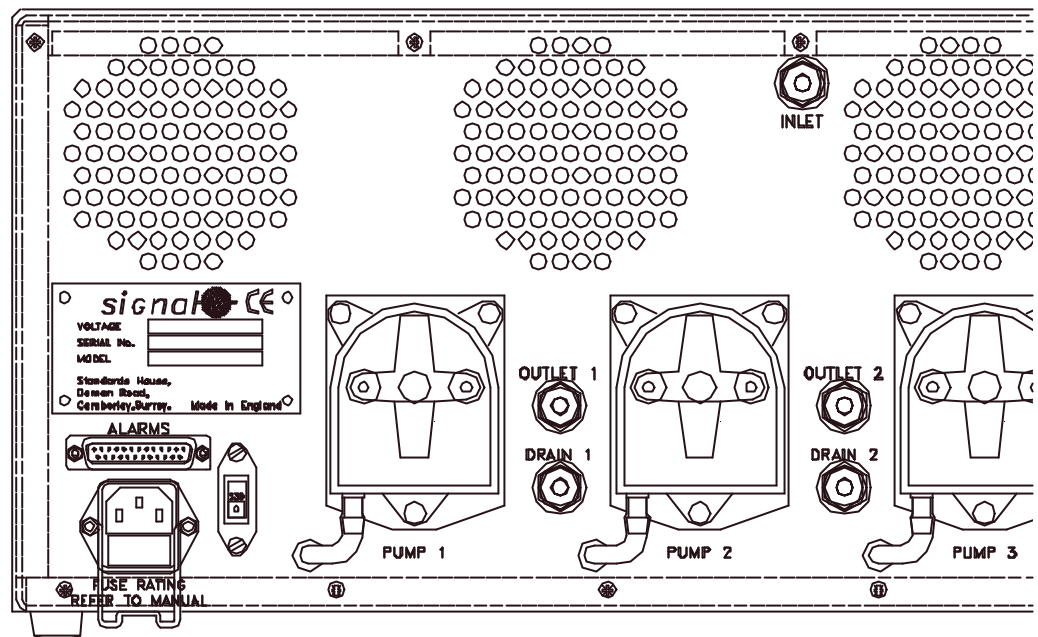

Figure 13 Peristaltic Tube Connections

8.1 Catch Pot Water Removal

- 8.1.1 Once per month, or more frequently if necessary, check for any collected water in each catch pot.
- 8.1.2 Disconnect the inlet pipe to allow water to drain.
- 8.1.3 For each channel in turn :-
 - 8.1.3.1 Place a receptacle under the drain port and remove the drain cap. When water no longer drains from the port replace the cap.
- 8.1.4 If water was present in the catch pot, run the cooler with sample flow for 24 hours to evaporate the last drops of water.
- 8.1.5 If, for convenience, you connect all the drain ports together while draining the water, **EACH CHANNEL MUST BE SEPARATELY CAPPED WHEN FINISHED otherwise cross channel sample flow can occur.**

8.2 Peristaltic Pump Tube Replacement

- 8.2.1 The peristaltic pump uses a flexible tube as the pumping mechanism. This tube will suffer from fatigue over a period of time and will fracture. This will cause sample leakage and a build up of water within the cooler chamber. If this water builds up so that it is transferred to the safety catch pot, the alarm relay will operate.
- 8.2.2 Initially once every month, check the condition of the peristaltic pump tubes. Every three months, or more often if necessary, replace the tubes.
- 8.2.3 For each channel in turn :-
 - 8.2.3.1 Disconnect the external and internal drain connections at the pump tube nozzles.
 - 8.2.3.2 Remove the three screws securing the clear cover to the pump base and remove taking care not to trap or strain the tubing.
 - 8.2.3.3 Detach the tube from the cover.
 - 8.2.3.4 Fit a new replacement tube to the cover. Fit the cover to the pump base taking care to place the tube over the rollers and between the two retaining arms. The two arms prevent the tube from wandering off the rollers. We find it easier to fit the tube if the rollers are aligned vertically.

- 8.2.3.5 Ensure that the cover locates fully and secure it with the three screws.
- 8.2.3.6 Reconnect the external and internal tubing.

8.3 Fuse Replacement

- 8.3.1 The cooler is fused with either one or two fuses depending on the country configuration. Refer to section 2.8 for fuse values and types - they vary with the number of channels and the local mains supply. If a fuse blows again within 24 hours, an internal fault condition is likely to exist. Contact our service department to arrange for the cooler to be serviced.

8.4 Spares Kit

- 8.4.1 Part number 200/334010, contains maintenance spares for one channel.

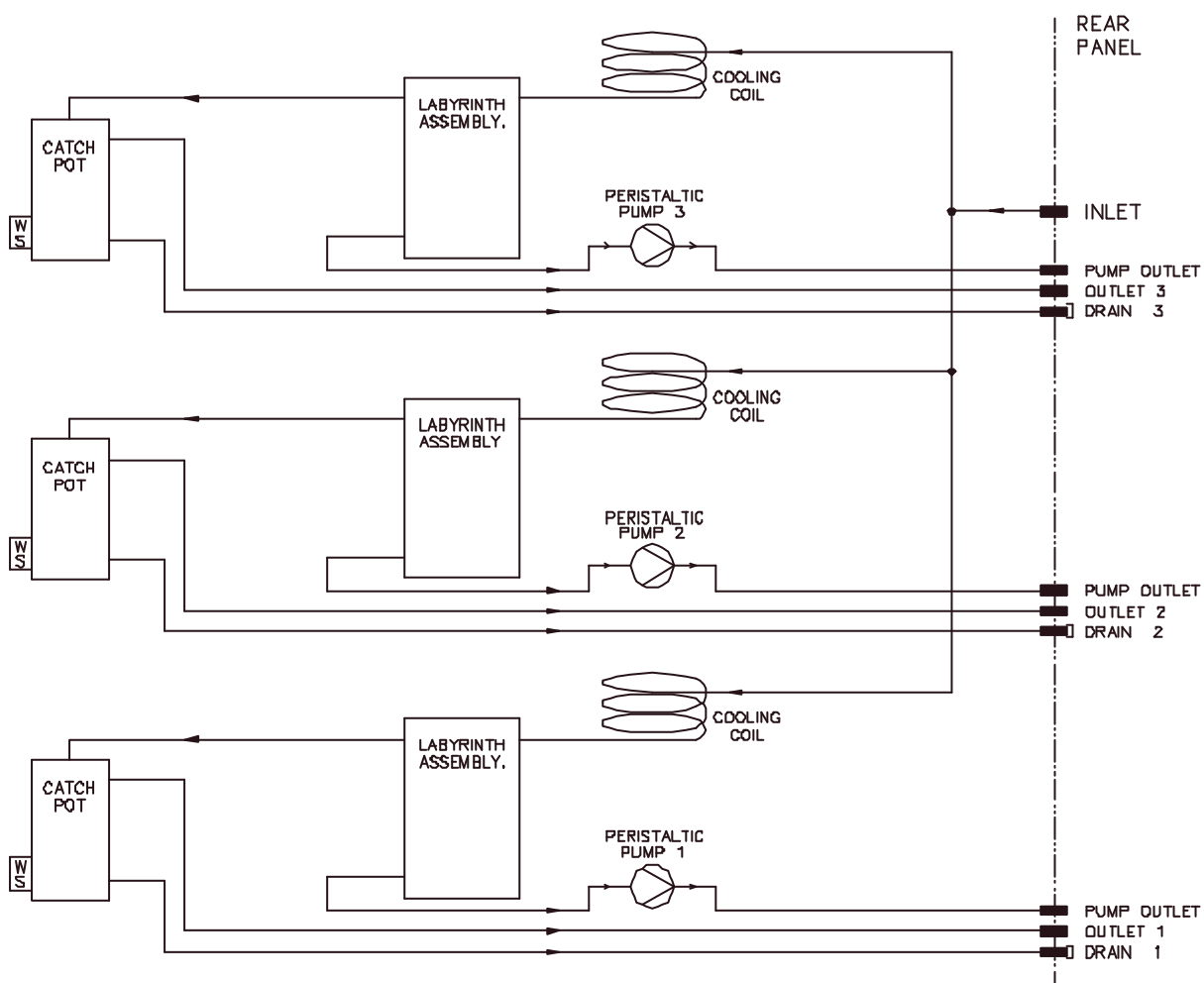

Figure 14 Flow Diagram (3 Channel)

9. ROUTINE SERVICING

9.1 Policy

9.1.1 Full service manuals are normally only issued to distributors and agents, but can be purchased by customers if they wish to carry out their own servicing. All warranty will cease, however, if a customer carries out his own servicing during the warranty period unless special arrangements have been made in writing.

9.1.2 If you wish to carry out your own servicing, contact Signal, your local distributor or agent.

9.2 Servicing

9.2.1 There are no user serviceable items inside the cooler. Should a malfunction occur, contact our service department and arrange its return.

9.2.2 Before returning your cooler, check that your mains supply is within the ratings in section 2.8 and that the correct fuse values and types are fitted.

9.2.3 Some examples requiring a return to the factory are :-

9.2.3.1 Frequent mains fuse blowing.

9.2.3.2 A channel POWER indicator is not glowing. First check that you have a model with that channel fitted. Refer to section 2.7 for model information.

9.2.3.3 Unable to cool to 5 °C with no sample flowing.

9.2.3.4 Water alarm on continuously after draining chatch pot and running for 24 hours.

9.3 Spares Kit

9.3.1 A one year spares kit, part number 200/334010, contains maintenance spares for one channel.

9.3.2 A two years spares kit, part number 200/334020, contains maintenance and service spares suitable for use by a field service engineer.

10. WARRANTY

For a period of 24 months from the date on which an instrument is delivered to the Purchaser, Signal Group Ltd. (the 'Company') will exchange or repair at the Company's option any part or parts requiring replacement or repair by reason of defective workmanship or material. This warranty applies to all new instrumentation manufactured by and purchased from Signal Group Ltd. subject to these conditions of sale:

1. The Company's obligations are conditional upon the goods being properly packed and despatched by the Purchaser to the Company's Works with transportation, insurance and other charges prepaid by the Purchaser. There is no charge to the Purchaser for the cost of the materials or labour time expended by the Company in discharge of its warranties. If a site visit is requested a charge will be made to cover the travelling and at the Company's discretion, subsistence expenses.
2. The Company shall not be responsible for any defect which, in the opinion of the Company, was attributable to:
 - a) Wear and tear. Certain components are, by their nature, consumables, and are excluded from warranty. Such items include catalyst material, lamps, filters etc.
 - b) Any form whatsoever of improper use or maladjustment or damage caused by the Purchaser, his employees or anyone other than the Company's personnel.
 - c) Abnormal corrosive or abrasive conditions.
 - d) Lack of regular servicing and maintenance of the instrument by Signal Group Ltd. or an authorised representative. Regular servicing is required according to the relevant maintenance schedule or every six months after delivery to validate warranty, and will be chargeable at current rates.
 - e) Non-compliance with any instructions issued by the Company concerning the use and fitting of the instrument.
 - f) Damage arising from installation or use of the goods in unsuitable environmental conditions.
 - g) Faulty or irregular supply of electricity, air, water, gas or other site services.
 - h) Modifications by unauthorised personnel.
3. The Company shall not be responsible for any expense which the Purchaser may incur in removing, replacing or fitting any part.
4. Every other form of liability, including consequential loss, damage or cost, howsoever caused, is hereby expressly excluded except where such loss or damage arises from negligence of the Company or its servants.
5. This warranty is given in addition to your statutory rights.